



CRANES FOR WASTE COLLECTION



HIGHER PRODUCTIVITY AND RELIABILITY WITH
WASTE COLLECTION CRANES IDEAL FOR
ACTIVITIES IN URBAN AREAS

HW LINE X



STANDARD FEATURES

- Designed in accordance with EN12999
- Load limiting device
- Have control valve 4 sections
- Multifunctional radio remote control
- Hexagonal section extension
- Independent extension cylinders

ACCESSORIES

- Slewing angle up to 330°
- 1 or 2 extra functions activated *
- 1 or 2 extra function not activated *
- Fixed stabilizers
- Open container cylinder (double hook system)
- Rotator 3T
- Worklights
- Hour counter
- Steel frame to install the crane on the roof

(*) Max of 7 functions on the control valve.
With 7 functions remote control Hetric Nova XL

HW60



Remote control:
HETRONIC NOVA L

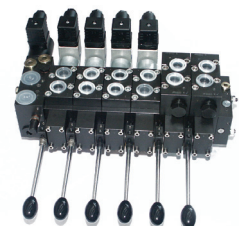

Control valve:
HAWE

- Pressure compensated control valve
- Protected against radio interference
- Move around the truck freely



Environment



Recycling



TECHNICAL INFORMATION HW60 X



DIMENSIONS (mm)

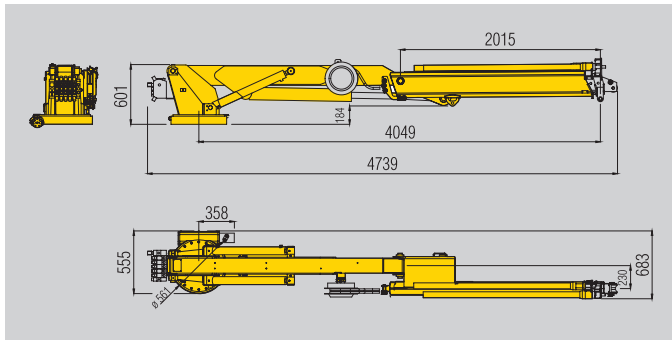

LOAD DIAGRAMS

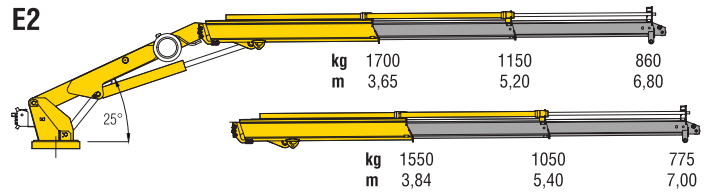

TECHNICAL SPECIFICATIONS

		HW60 E2
Maximum lifting capacity	tm	6,2
Maximum hydraulic reach	m	7,02
Maximum elevation height from the base of the crane	m	7,42
Working slewing angle	°	270
Maximum working pressure	bar	250
Weight crane	kg	750



WIDE ATTACHMENTS SELECTION



Container discharge unit H920-1 with ring system / low overall height



Container discharge unit H920-22 for containers with HYVA mushroom system



Container discharge unit H920-11 for containers with ring system



Container discharge unit H921 for containers with HYVA mushroom system or ring system



Container discharge unit H920-12 for containers with HYVA mushroom system

PERFECT FOR ALL COLLECTION SYSTEMS

Single ring

Only hook needed. Waste release in compactor with manual operation.



Double ring

One hook to lift the bin and the second to open/release the waste.



Mushroom

Special attachment needed to open the recycle bin.





Tipping Solutions | Container Handling | Waste Handling | Cranes

110 countries
+3,500 employees
20,000 customers
+30 subsidiaries
14 production facilities



Hyva is a leading provider of innovative and highly efficient transport solutions for commercial vehicles used in transport, construction, mining, materials handling and environmental service industries.

Founded in 1979 in the Netherlands, the company has a global presence with more than 30 wholly owned subsidiaries, extraordinary service coverage and 14 manufacturing facilities in Brazil, China, Europe and India.

For more information on Hyva, please visit www.hyva.com

or follow us on:



Hyva Holding B.V.
Antonie van Leeuwenhoekweg 37
2408 AK Alphen aan den Rijn
The Netherlands
Telephone: +31 (0)172 - 42 35 55
Telefax: +31 (0)172 - 42 08 80
info@hyva.com
www.hyva.com



Data, descriptions, and illustrations pertain only and uniquely to models sold at the time of printing of this brochure. After the date of printing, this information is purely indicative and not binding upon HYVA. Future modifications are solely at the discretion of HYVA and are always in compliance with applicable and pertinent safety standards. To obtain updated data, descriptions, and illustrations, contact the manufacturer or your reseller. Cranes manufactured and/or marketed by HYVA. HYVA is not responsible for the special applications depicted. Crane applications and accessories described herein are only examples. Some applications and equipment shown may not be approved for use in CE countries or other areas. It is the installer's responsibility to ensure that the crane is applied correctly, and that its application, installation, and accessories maintain safety and comply with all local laws.

M.K.T. 5800508 HW LINE DATE OF PRINTING: 04/05/2022