

**HA SERIES, THE PERFECT SOLUTION  
FOR APPLICATIONS WITH LIGHT VEHICLES**



**TELESCOPIC CRANE – COMPACT, LIGHT AND EASY TO USE**

**HA 21**



### ACCESSORIES

- Radio remote control
- Oil tank
- Supplementary element activation
- Winch
- Manual extensions
- Electro-hydraulic powerpack
- Extra cross beams
- Tubular base for crane stabilizers (single or double)
- Manually opening stabilizers
- Manually opening and turning outriggers
- "Green" Oil\*



Electro-hydraulic powerpack

## HA 21

- Compact dimensions and reduced weight
- Proportional speed control of any single movement
- Stabilizer control by radio



\*) Eco-friendly

## TECHNICAL INFORMATION HA 21

### DIMENSIONS (MM)

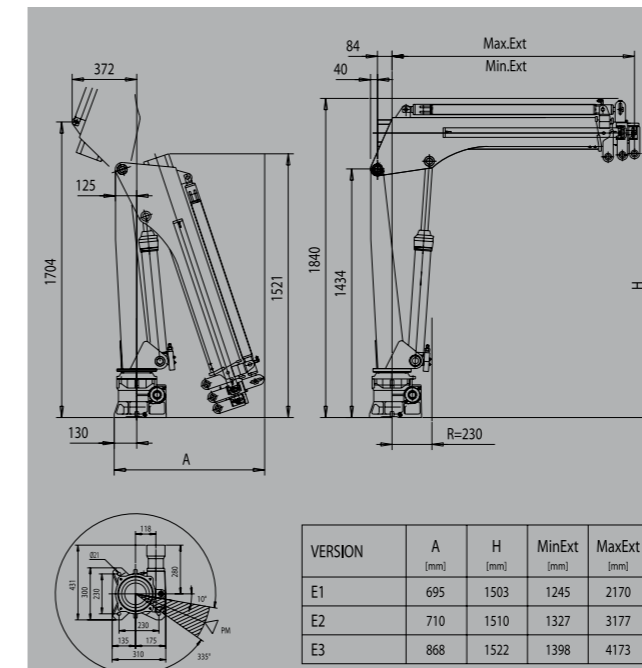

### LOAD DIAGRAMS

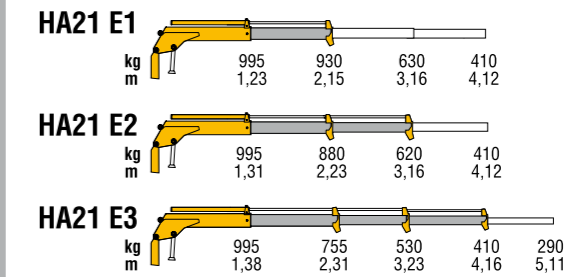

### STANDARD FEATURES

- Designed in accordance with EN12999
  - Design class: HC1-HD4
  - Hexagonal section extensions
  - Flanged valve
  - Assembly kit
  - Control panel with customizable position
  - ABS protective cover on controls
  - Worm and gear rotation
  - Fittings SAE-JIC
  - Sliding pads on telescopic extensions
  - Self-lubricating bushings
  - Independent telescopic cylinders
  - Light indicator for correct stabilizer stowing (CE)
  - Mechanical rotation limitation (CE)
  - Swivel stabilizer foot
- Thanks to their extremely compact dimensions all cranes in the HA series are projected to be mounted on small equipment such as: car trailer, tracked vehicle, pickup, small trucks and stationary mounting;
  - Control panel with customised position in order to always have the more ergonomic position;
  - Hexagonal extensions with sliding pads allow to always have rigid and aligned boom.

### TECHNICAL SPECIFICATIONS

		HA 21 E1	HA 21 E2	HA 21 E3
Lifting moment	<b>tm</b>	2,00	1,96	1,74
Max. vertical reach	<b>m</b>	3,56	4,51	5,45
Slewing angle	<b>°</b>	335	335	335
Slewing time	<b>s/180°</b>	10	10	10
Max. working heel	<b>°</b>	3	3	3
Working pressure	<b>bar</b>	160	160	150
Oil tank capacity	<b>l</b>	17,5	17,5	17,5
Max. oil flow	<b>l/m</b>	8	8	8
Standard crane weight (without stabilizers)	<b>kg</b>	216	240	262



**130 countries**  
**2,500 employees**  
**25,000 customers**  
**37 subsidiaries**  
**12 production facilities**



**Hyva is a leading provider of innovative and highly efficient transport solutions for commercial vehicles used in transport, construction, mining, materials handling and environmental service industries.**

**Founded in 1979 in the Netherlands, the company has a global presence with 37 fully owned subsidiaries, extraordinary service coverage and 12 manufacturing facilities in Brazil, China, Europe and India.**

For more information on Hyva, please visit [www.hyva.com](http://www.hyva.com)

or follow us on:



**Hyva Holding B.V.**

Antonie van Leeuwenhoekweg 37  
2408 AK Alphen aan den Rijn  
The Netherlands  
Telephone: +31 (0)172 - 42 35 55  
Telefax: +31 (0)172 - 42 08 80  
[info@hyva.com](mailto:info@hyva.com)  
[www.hyva.com](http://www.hyva.com)



**Quality and  
environmental certified**

**DEALER STAMP**