

EDGE LINE
RAISE YOUR GAME



TELESCOPIC CRANES EASY TO USE
HT 162



RAISE YOUR GAME HYVA PERFORMANCE



TOP SOLUTIONS

1 TPP

- **Top protection painting** - Top quality cathaphoresis treatment and paint process on all crane components ensures higher value retention and durability.
- Bolts and nuts protected by Geomet® treatment: 890% more resistance against corrosion.

Top quality protection for harsh environment



2 EES

- **Extra Extension Speed** - The market is always demanding more speed along with the highest possible safety. EES is the answer. Through the use of a specially designed counterbalance valve, this system increases the extension speed without affecting the crane's safety.

Save time, precise work, increase efficiency

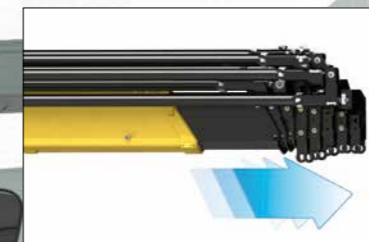

3 DLD

- **Dynamic Load Diagram** - After the stabilization, operator can select the load to be lifted. Display shows the permitted crane outreach based on the stability and the load selected.

Crane lifting capacity always under control in all stabilizer positions



4 SDS

- **Smooth Descent System** - Uses a special counterbalance valve to reduce boom oscillation, the result for the user is incredible precision in unloading operations.

Control and precision of the movement

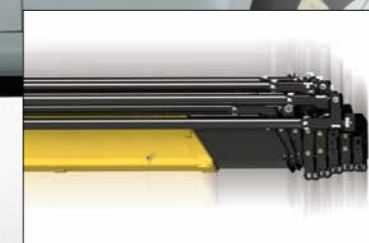



CRANE CONTROL SYSTEM

A

A-CLASS

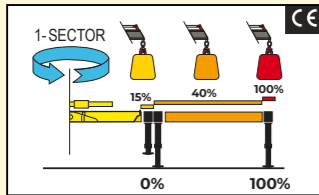

- N.2 step stabilizer beams
- N.1 sector on slewing
- Mono-area pressure limit

E

E-CLASS

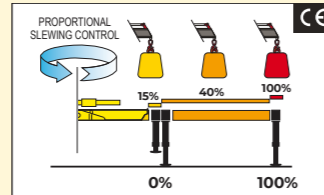

- N.2 step stabilizer beams
- Proportional slewing control
- Truck side independent

P

P-CLASS

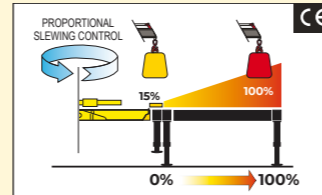

- Proportional stabilizers control
- Proportional slewing control
- Truck side independent

HUMAN MACHINE INTERFACE

L

BRIGHT LED PANEL

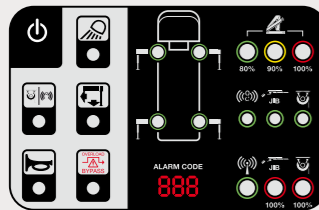

Available for the entire range till 28Tm. Highly user-friendly design, with buttons and LED lights. Dedicated led lights to identify the position of each stabilizer. New 3-digits display has been added to inform the operator about alarms and errors.

D

INTELLIGENT DISPLAY 4.3"



Up to 6 languages available. Full color new display. Offers more information and data compared to the LED Panel. The graphic design and intuitive menu guide the operator and service technician to all the functionality information, statistics and performances.

T

SMART TOP MONITOR 7"



Up to 16 languages available into the software. Top choice available for the range. Data statistics and crane management, all included into a 7" TFT monitor giving to the operator a higher level of awareness of the crane.

CRANE CONTROLS

M

MANUAL CONTROL



Crane with manual sequential controls have levers mounted on both sides of the crane. At each control station, the orientation of the controls can be the same up to down or left to right.

L

LCD REMOTE CONTROL



Each transmitter is equipped with 8 ergonomic proportional levers (6 for Scanreco mini) to control up to 8 functions of the crane. Using two hands, the operator can move 2-3-4 functions at once. This ensures more speed in loading or unloading operations with high precision.

G

GRAPHIC REMOTE CONTROL



Top visualization on 3" graphic display on the remote transmitter. Improved crane data visualization and crane control. Top level class of offer in the range.

SMART AND USER-FRIENDLY CONTROLS

Control station distinguished by operator comfort and user-friendly interface derived from dedicated ergonomic and user preference studies



SMART TOP MONITOR 7"
Simple and quick access to all the functions and information

Vertical stabilizers levers
Safe and fast. Excellent supervision of stabilizing operation

TECHNICAL SOLUTIONS TO RAISE RELIABILITY AND SAFETY

New Stability Logic for maximum level of flexibility

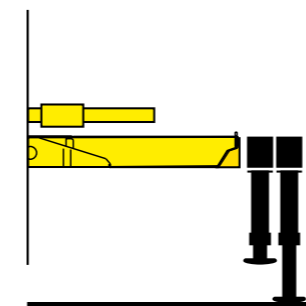

- Be free to maximize the use of your crane for all stabilizers' positions.

Compact built installation



- The extension cylinder layout has been designed to achieve compact boom and perfect alignment of the extensions. This construction allows to operate in confined spaces and with high precision.

Electronics mind: guaranteed in all conditions



- All electrical components have IP69K enclosures which offer complete protection against water jet and dust penetration providing higher durability and less down time.

OUR INNOVATIONS ARE CHANGING THE GAME

Solutions that are the result of smart engineering



DLD DYNAMIC LOAD DIAGRAM

This system, a first on truck-mounted articulated cranes, optimises stabilisation and makes crane operation safer and more efficient, allows the driver to verify in advance the crane lifting capacity based on the truck stability. A display shows the outreach available for the load selected and the actual boom slewing position.



TECHNICAL INFORMATION HT162

Dimensions (in)

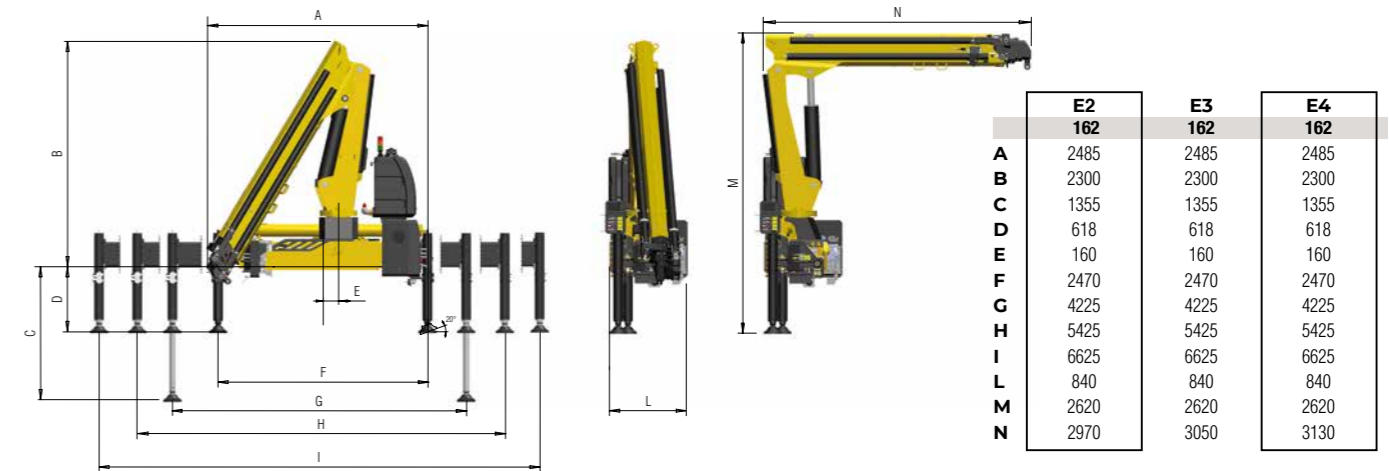

Load diagrams

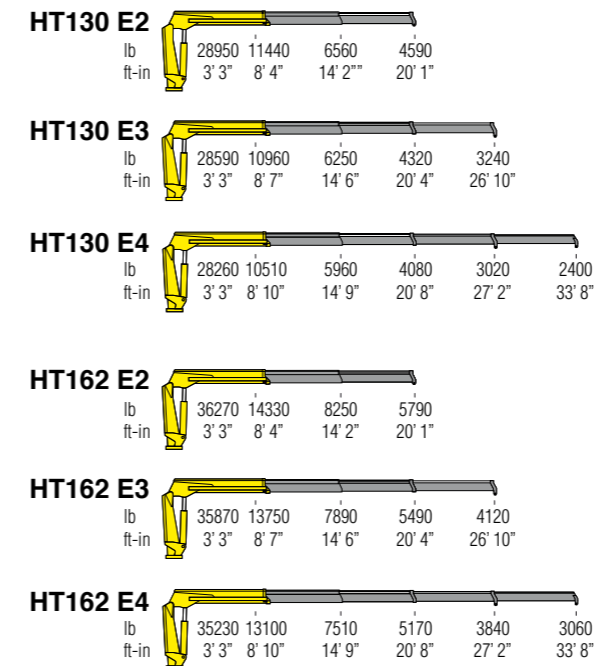

Standard features

- Designed in accordance with:**
EN12999:2020 + EN13849
Design class: HCl-D4
- Cross controls
 - Load limit device
 - Flanged valves
 - Oil tank
 - Manually extendable stabilizers
 - Internal stabilizers pipes
 - Fixed stabilizer cylinders
 - Swivel stabilizer foot
 - Centralized greasing system
 - SDS Smooth Descent System
 - A Class - Crane Control System (CE)
 - LED panel - Human Machine Interface (CE)

Technical specifications

		E2	E3	E4
HT		162	162	162
Lifting Moment	lb-ft	118600	117900	115700
Slewing Angle	°	425	425	425
Working pressure	psi	4200	4200	4200
Oil tank capacity	gal	34,3	34,3	34,3
Max Oil flow	gal/min	15,9	15,9	15,9
Max lifting height	ft-in	32' 0"	39' 0"	45' 5"
Standard crane weight	lb	3570	3825	4025

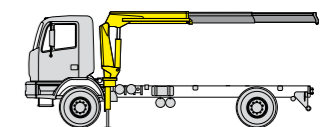

Recommended truck:
HT130
G.V.W. lb 28665
HT162
G.V.W. lb 35280

110 countries
+3,500 employees
20,000 customers
+30 subsidiaries
14 production facilities



Hyva is a leading provider of innovative and highly efficient transport solutions for commercial vehicles used in transport, construction, mining, materials handling and environmental service industries.

Founded in 1979 in the Netherlands, the company has a global presence with more than 30 wholly owned subsidiaries, extraordinary service coverage and 14 manufacturing facilities in Brazil, China, Europe and India.

For more information on Hyva, please visit www.hyva.com

or follow us on:



Hyva Corporation
300 King Street,
Elk Grove Village, IL 60007
USA
Telephone: +1 630 227 9020
Fax: +1 630 227 9029
salesusa@hyva.com
www.hyva.com
www.hyvacrane.com



Quality and
environmental certified



Data, descriptions, and illustrations pertain only and uniquely to models sold at the time of printing of this brochure. After the date of printing, this information is purely indicative and not binding upon HYVA. Future modifications are solely at the discretion of HYVA and are always in compliance with applicable and pertinent safety standards. To obtain updated data, descriptions, and illustrations, contact the manufacturer or your reseller. Cranes manufactured and/or marketed by HYVA. HYVA is not responsible for the special applications depicted. Crane applications and accessories described herein are only examples. Some applications and equipment shown may not be approved for use in CE countries or other areas. It is the installer's responsibility to ensure that the crane is applied correctly, and that its application, installation, and accessories maintain safety and comply with all local laws.