



**40 TON FLOOR LEAK RESISTANCE
ASSEMBLY INSTRUCTIONS**

40 TON FLOOR LEAK RESISTANCE ASSEMBLY INSTRUCTIONS

Introduction

The assembly instructions outlined in this book will enable you to assemble the Hyva Floor system you have purchased correctly. Every effort has been made, by means of diagrams and text, to ensure a clear and simple installation. To ensure the durability and reliability of this revolutionary loading and unloading system, it is important that you follow the assembly instructions as outlined in this book completely, and use quality materials in accordance with the specifications. Please note that the guarantee is only valid if the Hyva Floor system has been assembled in accordance with these assembly instructions. The latest available version can always be found on our internet site: www.hyva.com.

The measurements given in this instruction start with the metric system after which between brackets [0] the imperial measurement is mentioned.



If the indications in this manual, as well as those stated in the user manual, are not followed this could result in damages and/or injuries.



If your customer had any specific wishes we advise you to contact Hyva Floor This especially when what is wished for differs from the so-called normal use.

40 TON FLOOR LEAK RESISTANCE ASSEMBLY INSTRUCTIONS

Table of contents

Introduction.....	Error! Bookmark not defined.
Table of contents.....	3
Identification plate.....	4
Stickers.....	5
Important recommendations and guidelines.....	6
Emergency stop.....	9
Hoisting instructions.....	10
The chassis.....	11
Positioning the system.....	12
Height check and alignment of the Hyva Floor system.....	13
Securing the system.....	14
Bracing the side walls.....	16
Connecting the hydraulics.....	17
Choke.....	18
Preparing the profiles.....	19
Determining the Leak Proof subdeck length.....	19
Cutting out the openings in the Leak Proof subdeck.....	20
Determining the right width of the side profiles.....	22
Placing and mounting the first under floor profile.....	23
Secure the other under floor profiles.....	24
Finishing the edges of the under floor.....	26
Mounting the plastic bearing profiles.....	28
Determining the length of the top profile.....	31
Transfer execution.....	32
Drill mounting holes in the profiles.....	33
Drilling the holes in the floor profiles.....	34
Securing the floor profiles to the drive unit.....	34
Mounting the control box and the electrics.....	35
The moving headboard.....	37
The moving headboard tarpaulin.....	38
Adjustment of the threaded rod of the control valve.....	39
Technical specifications.....	40
Maintenance instructions.....	41
Important instructions.....	42
Troubleshooting E-control.....	43
Warranty conditions.....	45

TABLE OF CONTENTS OF THE ENCLOSED DRAWINGS

Attention: choose the system type that you are building in!!!

Subject	Drawing
System HF500 SLC H80 15-160.....	HF50811-SLC-200
System HF500 SLC H100 15-160.....	HF51026-SLC-200
System HF500 SLC H120 15-160.....	HF51202-SLC-200
System HF500 SLC H140 15-160.....	005464
Hydraulic drawing HF500 SLC A.....	H1-A
Hydraulic drawing HF500 SLC B.....	H1-B
Hydraulic drawing HF500 SLC E.....	H1-E
Proposal drawing hydraulic connections HF500 SLC.....	H2
Electric drawing E.....	E1
Electric drawing B.....	E2
Control valve E.....	BV1
Control valve B.....	BV2

Identification plate

General extended identification plate

Next to the system number the Hyva Floor order number will be mentioned and a field with 9 digits has been added in which we can, if required, put your identification or order number.

Numbers are automatically provided with a barcode; this makes it possible for you to scan the required data.

Short small identification plate

An extra identification plate has been mounted near the rear bridge, above the threaded rod of the control valve, so the system number can be read simply and swiftly at the outside of the trailer.

Paint and dirt protection

The identification plates are specially fitted with a double layer of transparent protective foil. The first protective foil has a lip with remains visible when the Hyva Floor system has gotten painted or exceptional dirty. This protective foil can simply be removed so the data is readable again and the second protective foil remains intact so the data remains protected.

		Hyva International B.V. A. van Leeuwenhoekweg 37 2408 AK Alphen a/d Rijn The Netherlands		Phone: +31(0)172-423555 Fax: +31(0)172-420880 e-mail: info@hyva.com www.hyva.com	
SERIAL NO. :	<input type="text"/>	YEAR :	<input type="text"/>		
TYPE:	<input type="text"/>				
MAX. PRESSURE:	<input type="text"/>			CE	
MAX. LOAD:	<input type="text"/>				

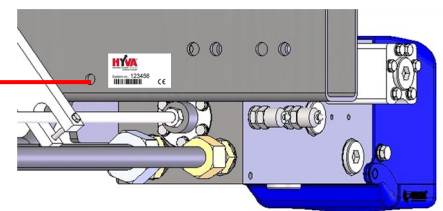
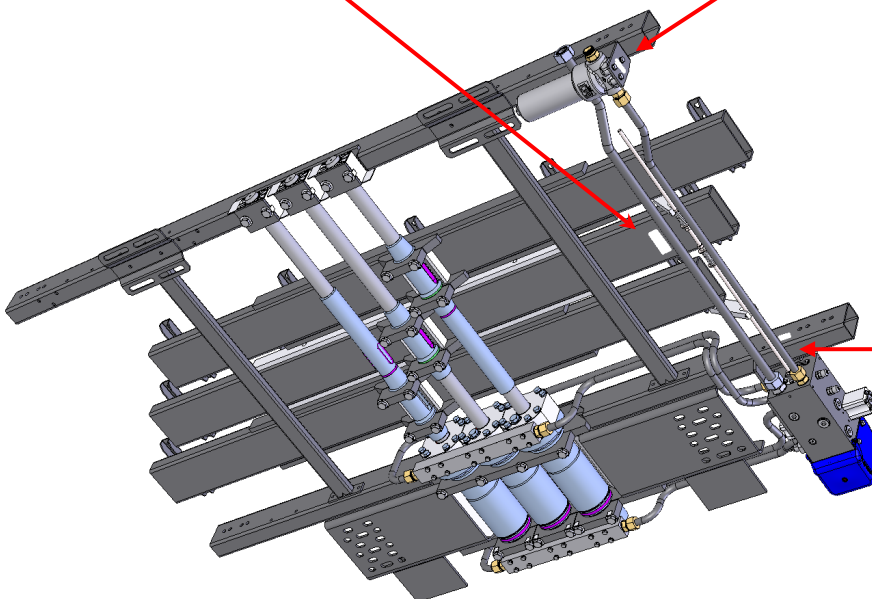
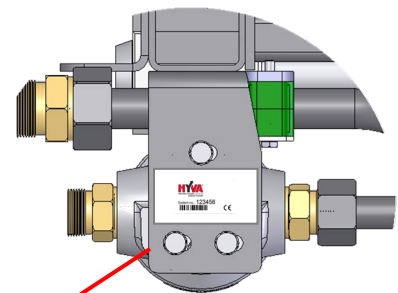

Stickers

This WARNING STICKER/DECAL has been supplied with the drive unit in two fold. It should be attached near the control box and on the rear door in such a way that it is easy to read.

A

STICKERS/DECALS ON THE CONTROL BOX, ONLY WITH B- AND E-CONTROL



STICKERS/DECALS ON THE SWITCHES

Switch B-control

Switch B-control

Switch E-control Switch E-control

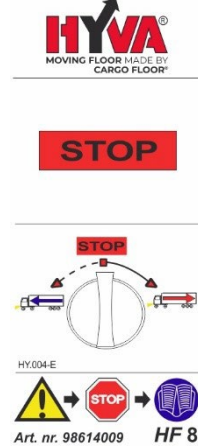
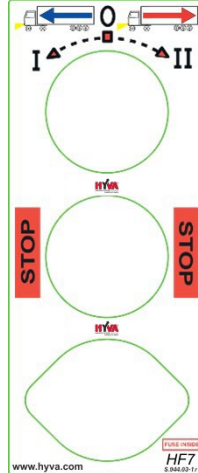
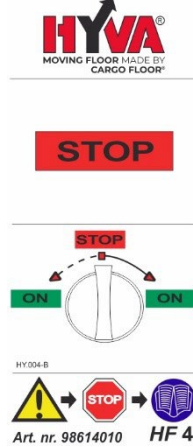
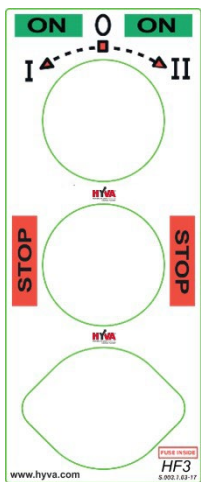

B

STICKERS/DECALS ON THE SIDE OF THE TRAILER, NEAR THE DRIVE UNIT

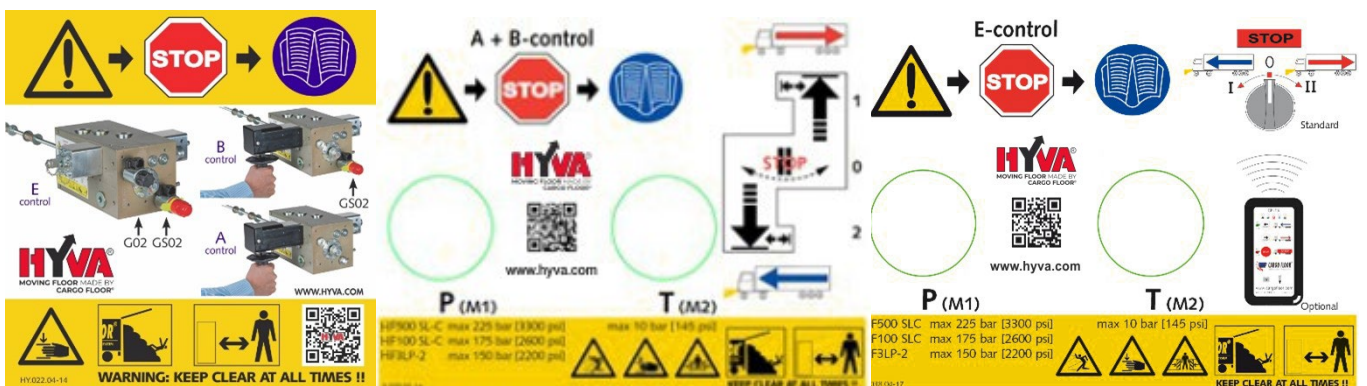

Only A + B-control



40 TON FLOOR LEAK RESISTANCE ASSEMBLY INSTRUCTIONS

Important recommendations and guidelines

Before putting the Hyva Floor loading and unloading system into operation, follow the recommendations provided below and check the specified checkpoints to avoid damage to the Hyva Floor system and the vehicle. Please review the important instructions before operating the Hyva Floor system and loading cargo into the vehicle. Likewise, before loading cargo, check the operation of the various control switches/valves to familiarise yourself with how the system works. We strongly recommend that you perform these checks when picking up the vehicle from the dealer so that your skilled supplier can answer your questions and provide you with any necessary advice or guidance you may require.

Important:

- Always check that the selected loading or unloading direction is actually activated and occurring!!
- If the system fails to start, turn off the Hyva Floor system and the hydraulic pump and follow the recommendations and guidelines provided below. Do not repeatedly try to start the system as this may result in damage to your Hyva Floor system and/or vehicle.
- After use, turn off the Hyva Floor system and hydraulic pump. Set switches to the "0" position and the lever in neutral.

In case of doubt or uncertainty about these recommendations and guidelines, always contact your dealer or an official workshop.

The Hyva Floor system comes standard with an operating manual, but if this has not been supplied, please contact your dealer or download it from the official Hyva Floor website: www.hyva.com, download.

- A) Always open the vehicle's doors before turning on the hydraulic pump. Note! Build-up of pressure against the doors can open them with force. Also some of the cargo can fall out of the vehicle by itself after opening the doors, therefore KEEP CLEAR AT ALL TIMES, product could fall on top of you! Both could result in damages and/or injuries! It is always advisable to use the pneumatic door lock, if provided.
- B) 1. Check that the vehicle's (quick-detachable) couplings are properly connected to the P (Pressure line) and the T (tank/return line). Also check that the couplings are fully tightened or slid completely into each other.
IMPORTANT: the pressure and return line connectors may not be reversed or exchanged to prevent dirt or water from entering the lines when connecting them!
2. Before connecting, check that the non-return valves can open easily (check: the non-return valves should open easily when pressed with the finger, if not, potential pressure build-up in the hydraulic lines may be preventing the system from starting).
NOTE: Incorrectly connected or unopened hydraulic couplings will cause serious damage to the Hyva Floor system and the vehicle.
- C) The vehicle (pump) must be fitted with a pressure relief valve that is set at the maximum pressure according to the system, see the technical specs. If fitted, check that the dual-function lever (function: tipper/Hyva Floor) is in the Hyva Floor position. Pressure may not exceed the maximum adjusted and allowable operating pressure of the Hyva Floor system. An incorrectly adjusted pressure relief valve can cause damage to the Hyva Floor system and the vehicle.
- D) During operation, the (hand)brake of the vehicle must always be applied. You must, however, move the vehicle forward on time to unload it quickly in order to prevent unnecessary strain and wear to the floor and the vehicle.
- E) Use of a wireless remote control is permitted only if it is fully tested before the start of each loading or unloading operation. Always check if the function you have selected is actually activated and taking place. If, for example, you have accidentally pressed the load function when you actually meant to press the unload function, irreversible damage may occur to the Hyva Floor system and the vehicle.
- F) During operation of the Hyva Floor system, all existing STOP and control knobs/levers must be freely accessible.

40 TON FLOOR LEAK RESISTANCE ASSEMBLY INSTRUCTIONS

- G) The pressure filter element needs to be replaced at least once a year. If the couplings between the vehicle and the Hyva Floor system are regularly removed, it is advisable to check the pressure filter for dirt build-up and replace the pressure filter element more often, if necessary. If provided, also check the return filter (not supplied with the Hyva Floor). Failure to replace a filter element on time may cause damage to or malfunctions in the Hyva Floor system and the vehicle.
- H) Moving parts must be shielded. Always maintain at least 10 meter [30'] distance from the Hyva Floor system when it is in operation.
- I) In the event of malfunctions/maintenance work, you may approach the Hyva Floor system only if all equipment, including the hydraulic pump, have been shut off, and the Hyva Floor system and the electro-hydraulic aggregate have been disconnected from the power supply and pump.
- J) Regularly check and, if necessary, tighten any loose bolts that secure the aluminium floor profiles to the Hyva Floor system. All such checks can simply be performed inside the vehicle itself by qualified personnel. The Hyva Floor system must, however, be turned on in unloaded condition and the person performing the check must place his finger half on the floor profile and half on the bolt. There should be no appreciable movement/space between the floor profile and bolt. Failure to check these bolts may lead to damage to the Hyva Floor system. During this check, a second person must also be present to switch off the Hyva Floor system.
- K) Check that the minimum required amount of oil is present 150 liter [40 US gallon]. Too little oil in the hydraulic tank will cause damage to both the pump and the Hyva Floor system.
- L) Do not allow the number of strokes to exceed the maximum allowable 16 power strokes per minute. Only a HF500 SLC Power Speed Hyva Floor system may deliver up to 23 beats per minute. A higher number of power strokes can cause damage to the Hyva Floor system and the vehicle.
- M) Hydraulic lines, couplings and hoses with very small diameters will cause damage.
- N) If the Hyva Floor system fails to start or operates incorrectly, the Hyva Floor system and the hydraulic pump must be shut down immediately. Subsequently, check all the checkpoints before switching the pump and the Hyva Floor system back on. To prevent the oil from overheating, regularly check the oil temperature by CAREFULLY and CAUTIOUSLY touching the line and or oil tank. If either is too hot to the touch, stop touching them right away. **WARNING: TOUCHING OVERHEATED OIL AND COMPONENTS CAN CAUSE BURNS!**
- O) The cause of failure or malfunctioning of the Hyva Floor system may also be due to other hydraulic components that may or may not be connected to the same hydraulic circuit of the Hyva Floor system.
- P) Jamming of the floor profiles caused by the transport of abnormal loads and or the freezing of the floor or of the product to the floor may result in damage to the Hyva Floor system and the vehicle. Recommendation: in the event of freezing, stop the system and try to find a hall (heated area) to allow the product to thaw.
- Q) Because the electrical power supply of the Hyva Floor system is often connected to the lighting circuit of the vehicle, it is advisable to turn on the lighting throughout the operation of the system.
- R) Maintenance and repairs to the Hyva Floor system may be only performed by qualified personnel. Use only original Hyva Floor components to ensure maximum reliability and long service life.
- S) Maximum cargo weight is subject to the limits set by law and applicable regulations. Even if the system can transport heavier loads, the law determines the maximum limit. Excessively heavy cargo can cause damage to the Hyva Floor system and the vehicle.
- T) Check that the correct type and quality of hydraulic oil is used. The use of incorrect oil type may cause damage to the Hyva Floor system and the pump.
- U) Check the vehicle for correct voltage. Make sure there are no open electrical connections. A faulty electrical system can cause damage to the Hyva Floor system and the vehicle.
- V) Check that the bulkhead, if present, is functioning smoothly and properly. A properly functioning bulkhead ensures that the product is unloaded in a clean and quick fashion. A malfunctioning bulkhead may extend the unloading time and cause damage to the vehicle.
- W) Use of the Hyva Floor system by unqualified personnel can cause damage to the Hyva Floor system and the vehicle.
- X) Excessively high oil temperatures will cause damage to the Hyva Floor system and other hydraulic components, such as the pump.

40 TON FLOOR LEAK RESISTANCE ASSEMBLY INSTRUCTIONS

- Y) It is at all times advisable to stop the Hyva Floor system when all the piston rods are retracted. This is usually the case when the floor profiles are positioned towards the unloading end (vehicle doors). Un-retracted piston rods may cause damage to the Hyva Floor system.
- Z) To prevent damage to the floor profiles, exercise caution and limit the dump height as much as possible. The transport of unauthorised goods, such as aggressive, corrosive, hot, hard, sharp and viscous materials may cause damage to the Hyva Floor system and the vehicle. Avoid loading and unloading sharp objects. Loads that are softer than the hardness of the floor profiles will extend the service life of your system; if in doubt, use a protective cloth or consult your dealer.
- AA) Forklift trafficable. In principle, the floors are completely trafficable and can be driven over by forklifts, but always consult your dealer for advice on the maximum loads allowed on your vehicle. Overloading will cause damage to the Hyva Floor system and the vehicle.
- BB) Always return emergency control(s) to their original non-activated position after use.
- CC) During the operation of the system, test the temperature of the oil by touching the side of the tank. If the oil is so hot that you cannot continue to touch the tank, switch off the pump to allow the oil to cool off and determine what is causing the overheating. Stop loading or unloading if the oil is too hot, as this will irreversibly cause damage to the Hyva Floor system and the other hydraulic components.
WARNING: TOUCHING OVERHEATED OIL AND COMPONENTS CAN CAUSE BURNS AND INJURIES!
Option: your Hyva Floor system could be equipped with an oil temperature safety switch which will switch off the system automatically when it starts to overheat.
- DD) During loading and unloading operations, the load should be spread to give an even weight distribution over the floor area, otherwise the load may stall. Tip: when transporting pallets, place softwood boards of 300 x 18 x 2350 mm [12" x 0.75" x 92.5"] to distribute the pressure more evenly.
- EE) The constant pressing of the load against the head board or the doors can lead to extra wear of the complete system. Also the construction can be damaged. Please consult your supplier about the optimizing possibilities or in order to prevent problems occurring.
- FF) The user/operator/driver that is operating the Hyva Floor system is compelled to remain a safe distance from the Hyva Floor system at all times, from the time of switching on the hydraulic pump until turning it off. He should ensure that no dangerous situations can occur. When the process malfunctions or if other people are present he should shut down the Hyva Floor system, or hydraulic pump, immediately.
- GG) No unauthorized alterations/modifications/changes/adjustments may be made to any part of the Hyva Floor drive unit and system.

40 TON FLOOR LEAK RESISTANCE ASSEMBLY INSTRUCTIONS

Emergency stop

In the event of an EMERGENCY, operation of the Hyva Floor system can be halted as follows:

- By pressing the red stop button on one of the control switches;
- By turning all switches to position "0";
- By putting the handle of the control valve in the middle "0" position (only B and A control);
- Turning off the PTO pump/engine;
- Turning off the main switch of the power supply;
- Turning off the motor of the electro-hydraulic aggregate.

Hoisting instructions

Attention!

If your system has been supplied with piston rod protection, this protection needs to remain put until the end of the mounting process. It may only be removed just before you hand over the trailer to your customer.



Warning!

It is not permitted to lift the Hyva Floor system by the cylinders, moving crossmembers, valves or pipes.

You must use the hoisting points when lifting the Hyva Floor system (as shown in figure 2). You need to pay particular attention that you use the right set of hoisting tools during lifting so that the bearings and conduits do not get damaged.

Systems supplied in transport rack

The tilting plates mounted at the rear bridge are designed in such a way that they prevent damages occurring to the cylinder bottoms, conduits and valve when tilting the system onto blocks or directly onto the chassis.

Systems supplied on pallet

The Hyva Floor system can be mounted directly on the chassis. Great care must be taken while placing the Hyva Floor system to ensure that the system cannot slide away and cause danger and that there is absolutely no damage caused to the system.

FIG. 2

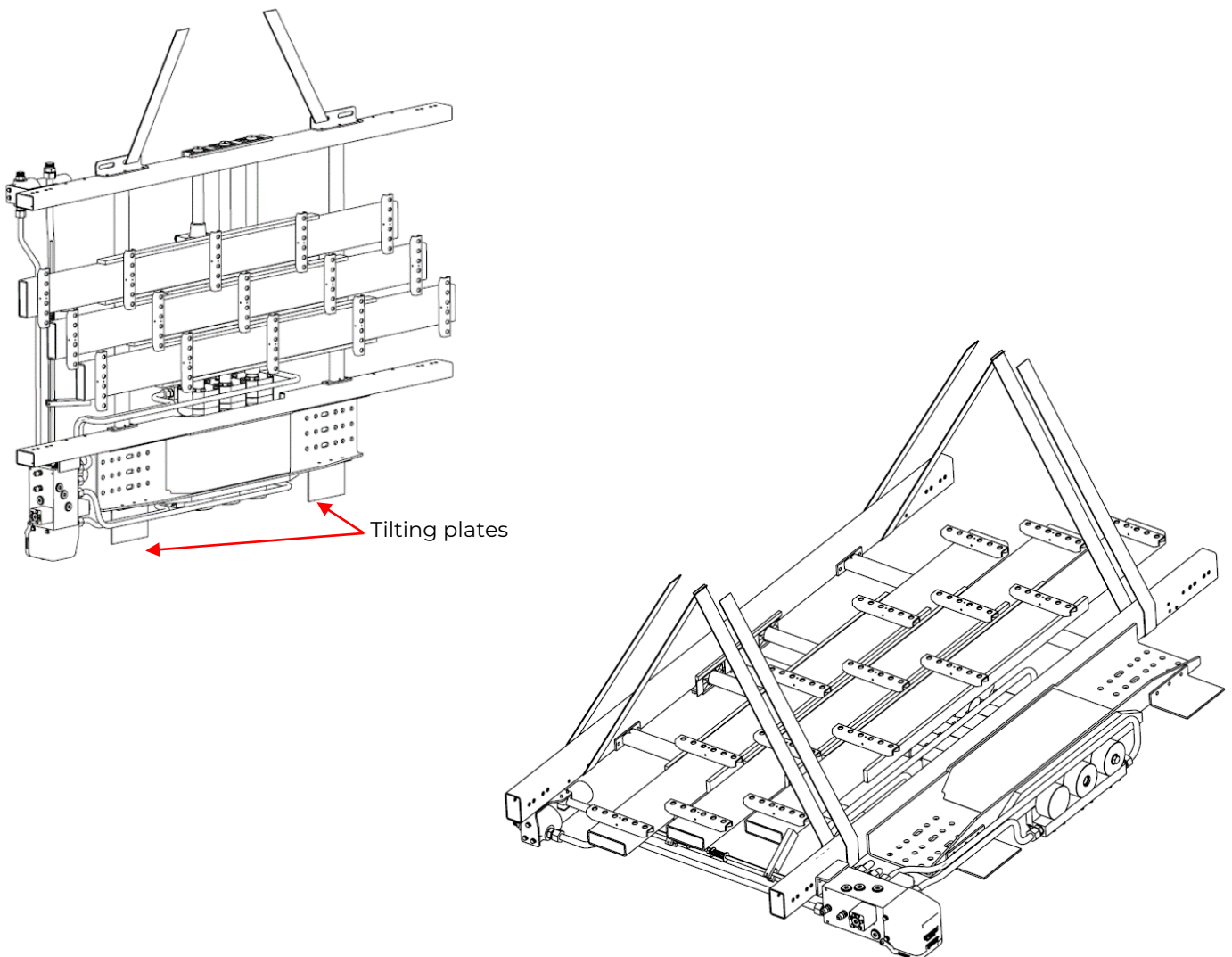

The chassis

For the assembly of the **HF500 SLC Leak Resist* "Centre Drive"** system will we advise you in chronological order how you, in our opinion, could do this the best way. The build of the chassis and the assembly of the **HF500 SLC Leak Resist* "Centre Drive"** system is almost done the same way as the standard HF500 SLC system.

It's very important to ensure that, during the installation of the Hyva Floor system, the crossbeams are flat on the chassis. There must be no difference in height between the crossbeams, as this would hinder the installation of the system and adversely affect the operation and the lifetime of the Hyva Floor system.



Attention: the u-profile needs to be connected to the front wall side with a watertight connection at the head board side.

FIG. 3

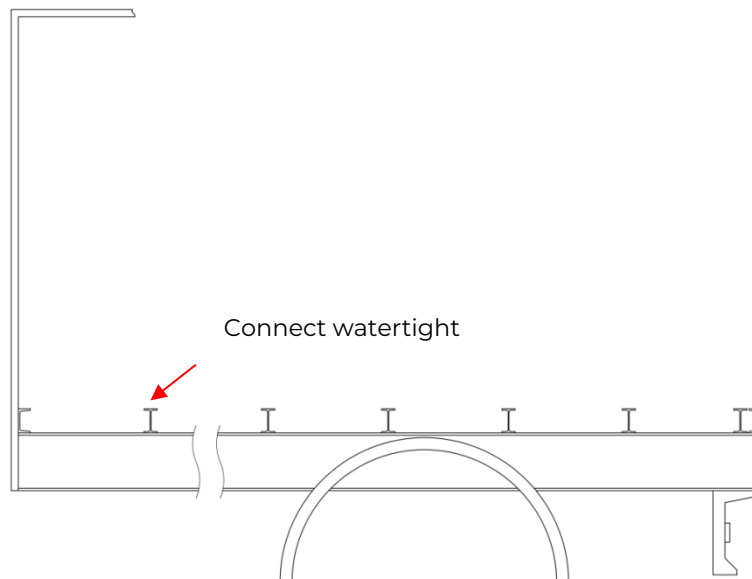

We refer you to figure 4 for the positions of the crossbeams. Make sure that there is space free in the middle of the chassis for the Hyva Floor system.

On the chassis the distribution of the remaining cross members must be done so sufficient support from the floor is there and the wall can be supported. The minimal distribution we advise is mentioned in fig. 4.

FIG. 4

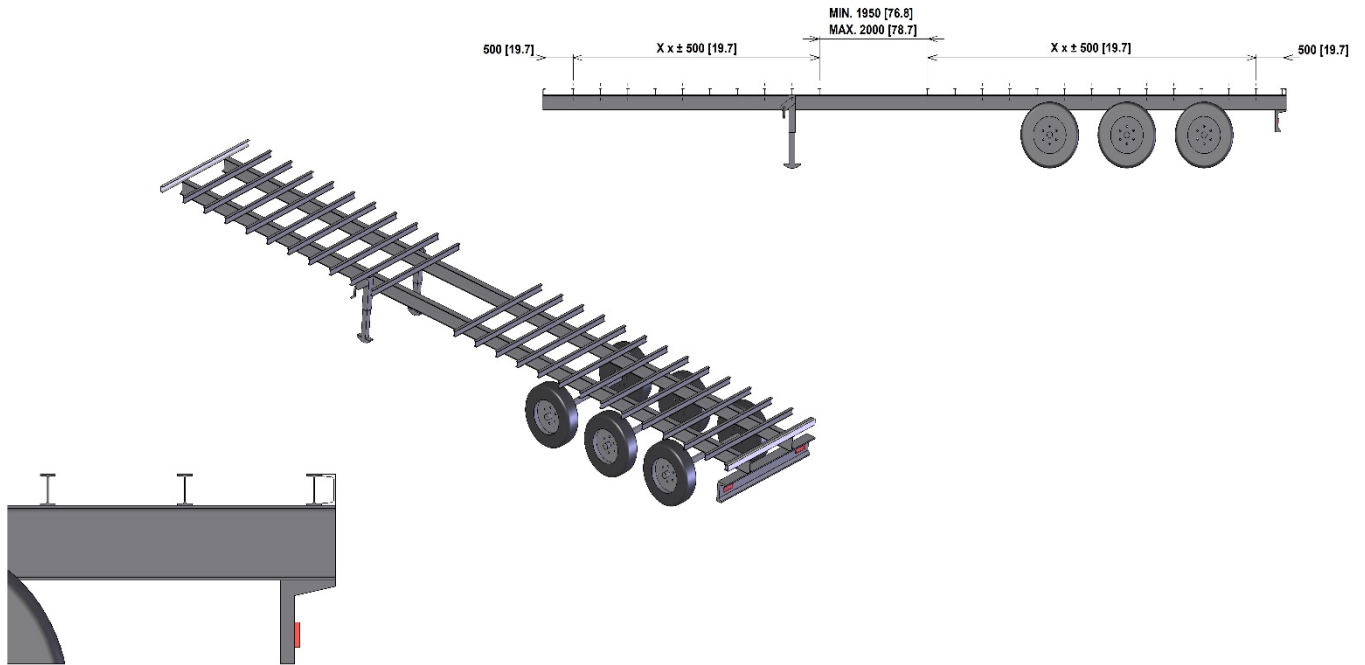

Positioning the system

The [hoisting procedures](#) need to be studied before placing the HF500 SLC system. The HF500 SLC system can now be laid in the appropriate opening on the chassis / frame (see figure 5), **noting that the piston rods must always point in the head board direction.**

FIG. 5

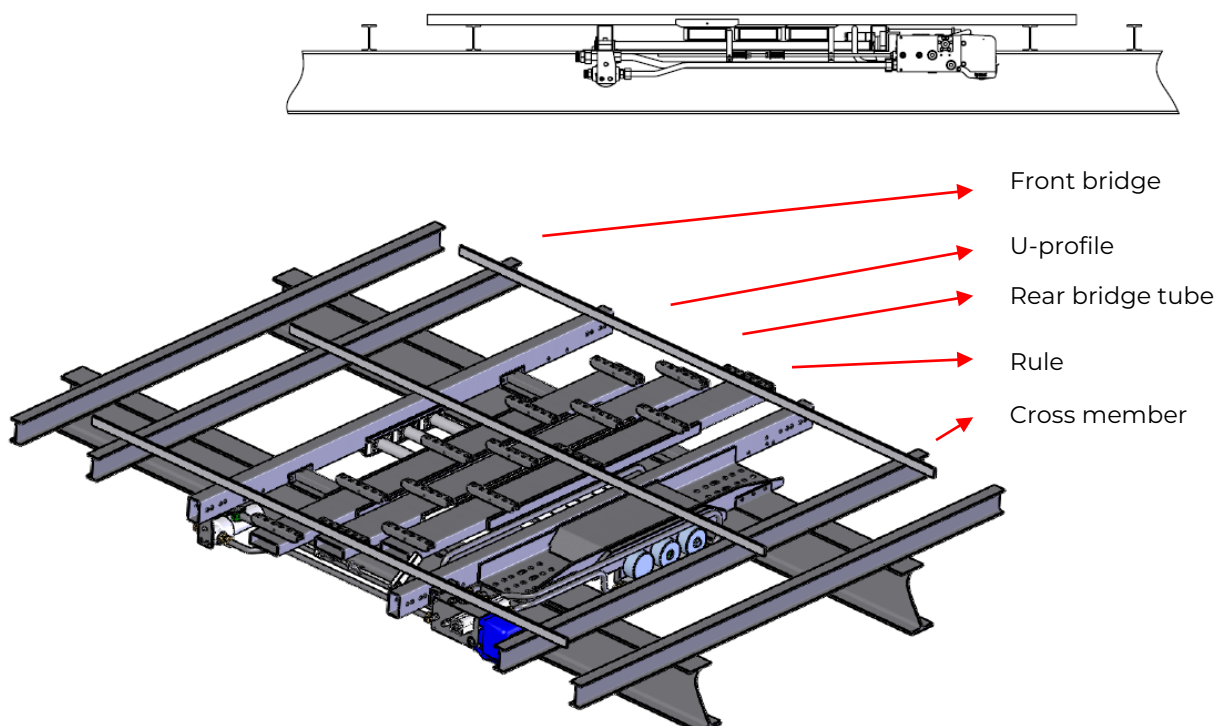

Height check and alignment of the Hyva Floor system

Height check

The Hyva Floor system needs to be made to the right height. You need to check the height at three places with the help of a rule between the fingers and over the cross members. The height of the top sides of the front and rear bridge tube of the Hyva Floor system is the same as the height of the cross members of the trailer itself. Any spaces that have arisen between the chassis / frame and the underside of the Hyva Floor system should be filled.

Alignment

It is extremely important that the system later on gets exactly lined up with the plastic profile bearing. In order to place the system in the middle and straight the piston rod of the middle cylinder is used as reference. The centre line of the middle cylinder (and also at the same time the middle u-profile of a 15 profile system) should run parallel with the centre line of the trailer itself. Tighten a string as reference for this centre line

It is advisable to clamp the Hyva Floor system securely once it is correctly positioned.

Securing the system

After the Hyva Floor system has been correctly positioned it can be secured to the chassis by welding or by bolting.

Bolting (see fig. 7 and 8)

The holes in the chassis should correspond with the mounting holes in the rear bridge and the front tube of the Hyva Floor system. 6 nuts per side need to be used on the rear bridge (see figure 7) and 1 nut per side in the so-called front bridge. This results in a total of 14 bolt connections. Each nut needs to be secured with a spacer and double nut (1x nut and 1x self-locking nut) (see figure 7).

All bolts must conform to the following specification:

14 pieces M16x80 ELVZ (DIN931-10.9) [5/8"x3.25"]. Quality 10.9. [grade 8].

14 pieces nut M16 [5/8"]

14 pieces lock/nut M16 [5/8"]

28 pieces washer $\varnothing 30 / \varnothing 17$, thick 3 mm (DIN125) [$\varnothing 1.25" / \varnothing 0.75"$, thick 0.12"]

14 pieces spacer ST52-3 $\varnothing 30 / \varnothing 17$, length 20 mm [$\varnothing 1.25" / \varnothing 0.75"$, length 0.79"]. Parts no.: 5451005

For an aluminium chassis we can advise, as an alternative to the spacers, to use a strip (thickness 20 mm. [0.79"]) with corresponding hole pattern.

Torque of the M16 nuts is 300 Nm [215 lbf.ft].

FIG. 7

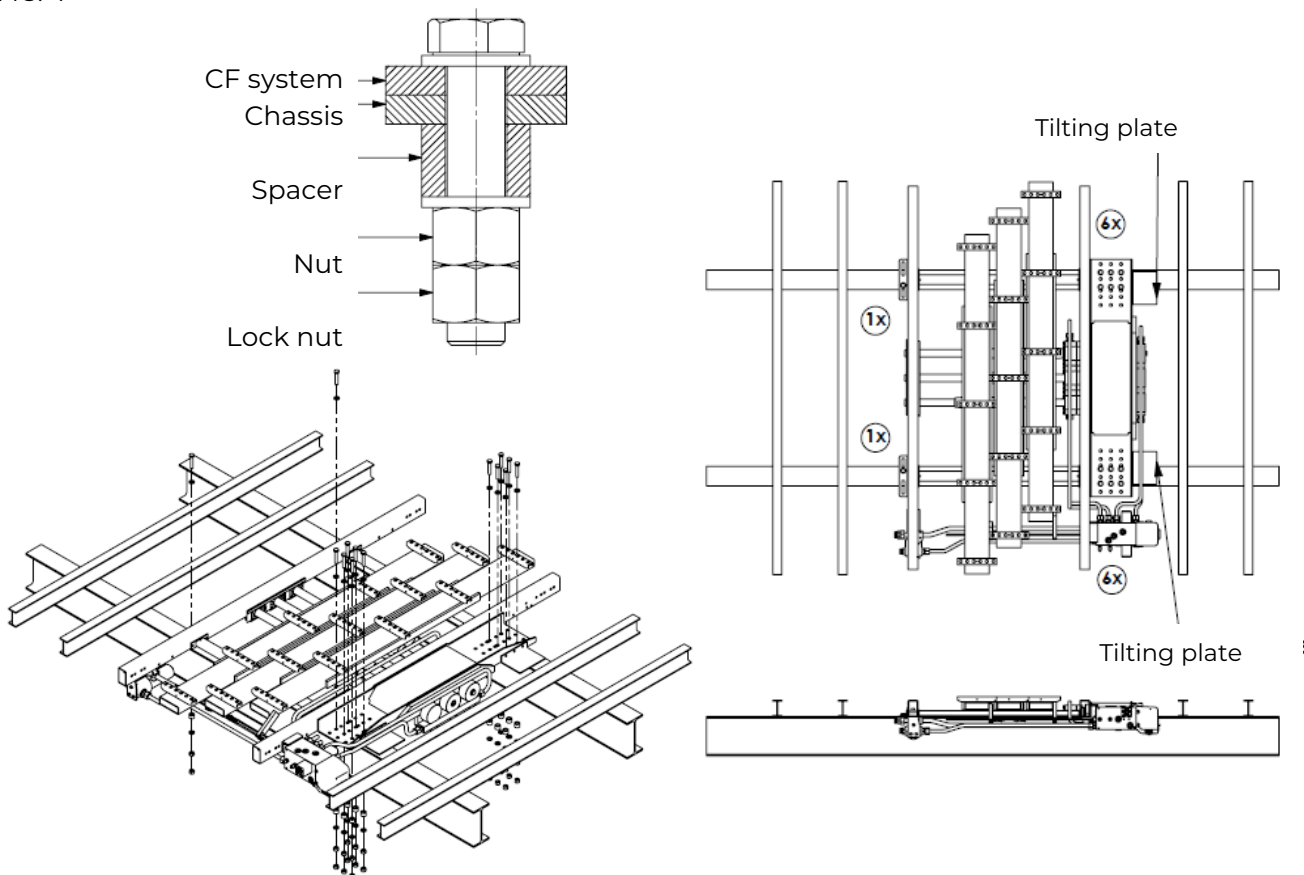

40 TON FLOOR LEAK RESISTANCE ASSEMBLY INSTRUCTIONS

Welds (see fig. 8)

Good quality welds, of the appropriate lengths, need to be made at the points indicated in the drawing (figure 8). The tilting plates (if present) at the rear side of the rear bridge need to be removed before welding the rear bridge to the chassis (figure 7).

Use a weld width of min. $a = 10$ [$a = 0.5$ "].

Bracing of the Hyva Floor system is not necessary.

Attention!

If the sub frame is zinced (option) the surfaces that need to be welded should have the zinc coating removed.

FIG. 8

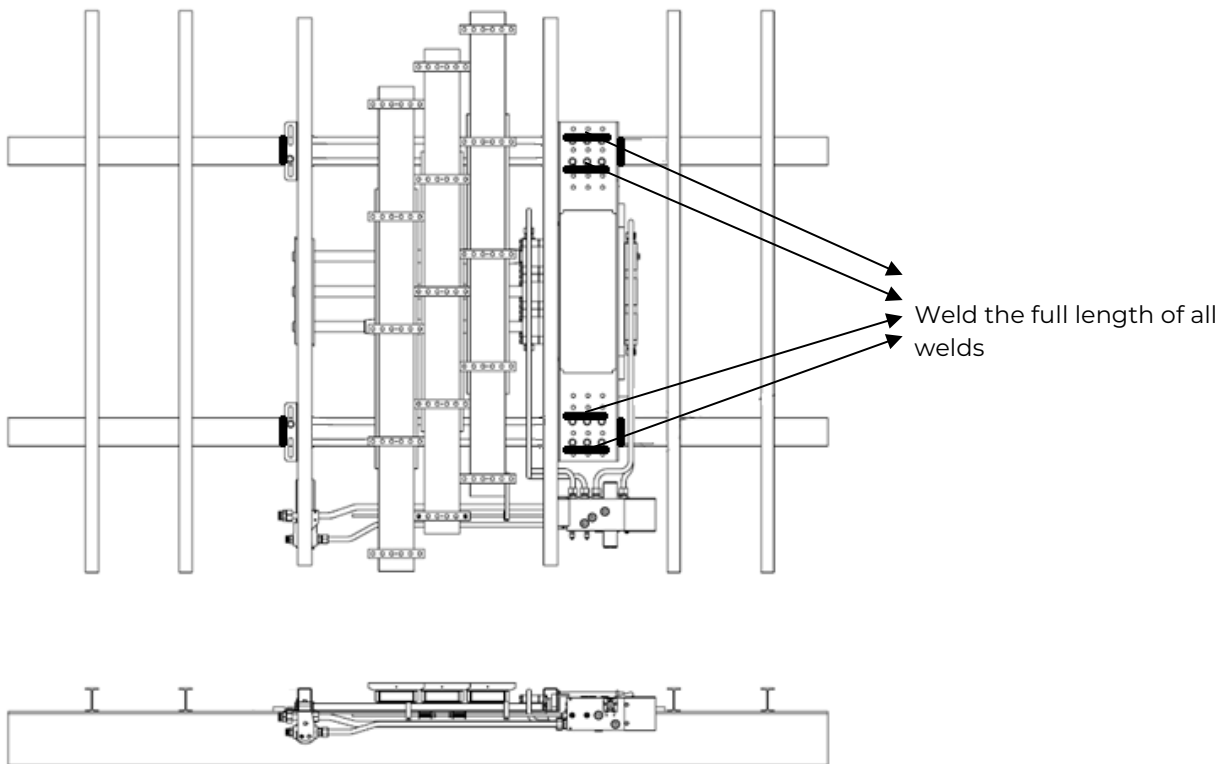

Bracing the side walls

The sidewalls of the Hyva Floor system are not supported since no crossbeams are used. This can lead to buckling of the sidewalls when the system is heavily loaded. This can be avoided by fastening the sidewalls to the chassis. Figure 9 shows how this can be done.

FIG. 9

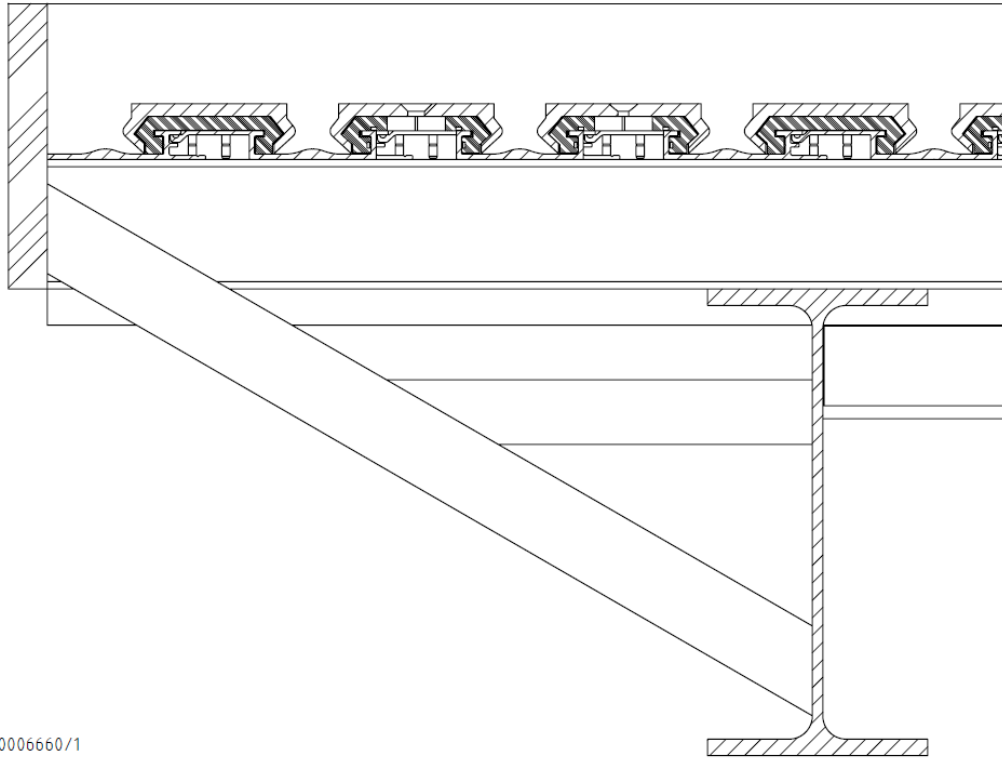

0006660/1

Connecting the hydraulics

FIG. 10

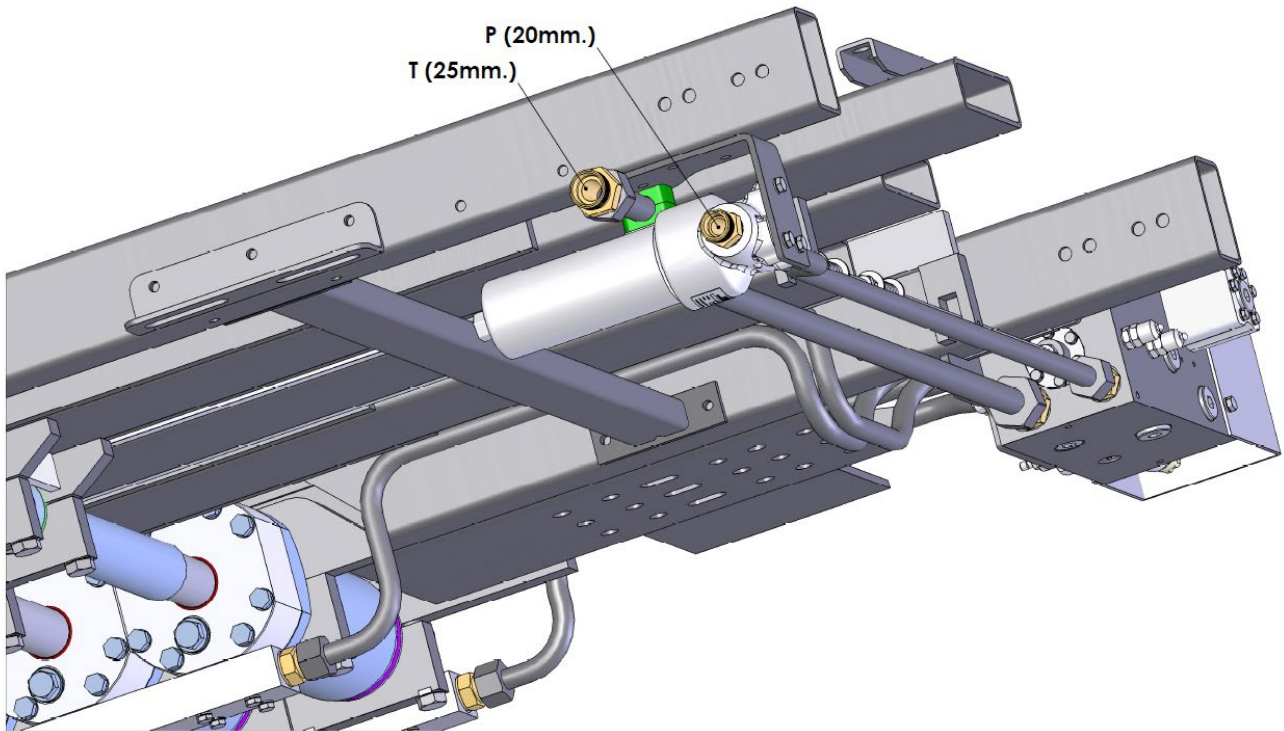

The Hyva Floor system is supplied as standard with a pressure filter already mounted on the front bridge, see figure 10. There is a hydraulic pressure pipe (Ø 20 x 2 feed through 16 mm) already mounted from the control valve to the pressure filter. The 'in' channel of the pressure filter is provided with a straight screw-in coupling 1" x 20 mm. Next to this is a hydraulic return pipe (Ø 25 x 2,5 feed through 20 mm) mounted from the control valve to the front bridge, ending in a straight connecting coupling 25-25 mm. You can connect the required hydraulic hoses (not included in delivered package) directly to these connectors (the supplied turnbuckles and cutting rings are not required then). If you mount a hydraulic pipe instead of hydraulic hoses then you can use the turnbuckles and cutting rings.



Important: connecting pressure and return wrongly will cause a malfunction, and damage to, the system.

All hydraulic components need to be carefully cleaned before being connected, making sure that no sealing caps / cleaning wads are left behind.

Try to use as few (square-)angled couplings as possible (as these cause pressure loss, or build-up of return pressure).

After connecting the system it may not be operated. Operation may only be done at the moment that the trailer and floor have been fully built!!!!

Choke

If the E-controlled Hyva Floor system will be operated by different types of pumps or a pump with a low oil flow, it could be that you have to pay attention to mount another type of choke.

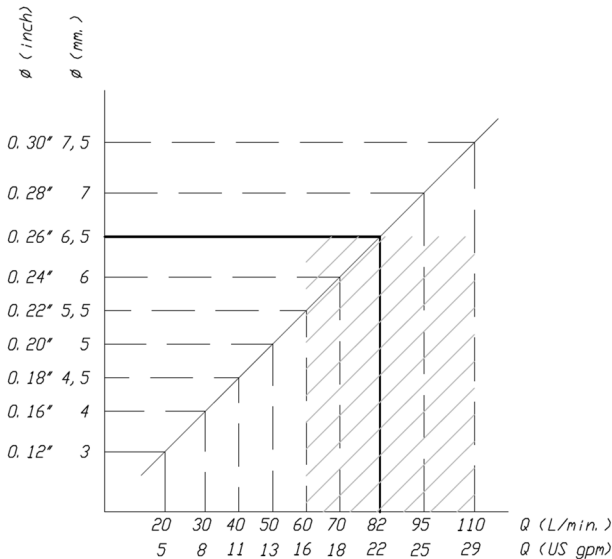

Standard choke
DIN 906-5.8-3/4"

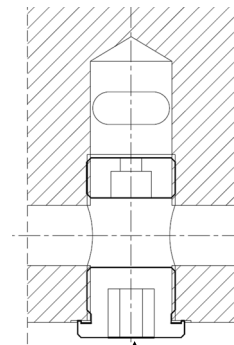

PB

Variabele choke
Art. nr. 7370106

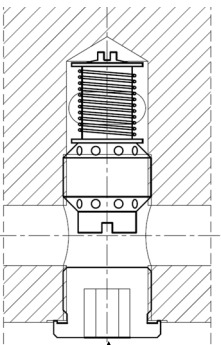

PB

The shading points out the reach of the standard choke.

Choke

There is a standard 6,5 mm [0.26"] choke mounted as standard in the PB channel of the E control valve. This allows the E control valve to function correctly. This standard choke is suitable for an oil flow level of 60 to 110 litres per minute [16 to 29 gpm]. The function of the control valve can be affected by a deviation from this oil flow level. The oil flow diagram shows which level of oil flow is required by which opening. Adjustment of this is possible by simply changing the diameter of the choke.

Known consequences of a wrong choke diameter are:

- Oil flow too low: load/unload operational plunger is not switching, system gets pressure less;
- Oil flow too high: noise in system, high heat dissipation and capacity loss.

Flow independent choke

As an option a flow independent choke can be supplied (variable choke article number 7370106). The standard mounted choke can simply be changed with these. You remove the socket plug out of channel PB (Allen key 12 mm). After this you screw the choke out of the channel with Allen key 12 mm. Screw the new variable choke in the channel and fasten these by hand (about 15 Nm [11 lbf.ft.]). Screw the socket plug back into channel PB (Allen key 12 mm) and fasten these by hand (about 15 Nm [11 lbf.ft.]). Let the floor run (loading and unloading) in order to check if everything is functioning well and no leakage occur. The variable choke has a flow range of 20-120 ltr./min [5-31 gpm] ±10% using a VG32 and is suitable for a maximal work pressure of 225 bar [3300 psi].



Important

Connecting pressure and return wrongly will cause a malfunction, and damage to, the system.

B-control

Another possibility to be independent from a variable oil flow is using a B-control. With this the loading/unloading direction is determined by a handle.

Preparing the profiles

FIG. 14

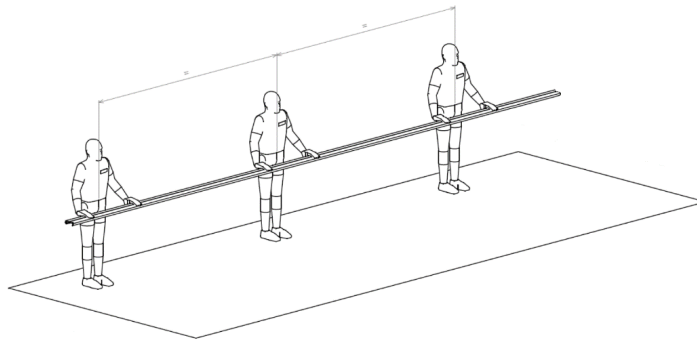

During the following activities and preparations you must take into account that the underprofiles as well as the top profiles are handled in such a way that the profile will not bend or be damaged in any other way. We advise to move or tilt the profiles with the help of at least three people.

FIG. 15

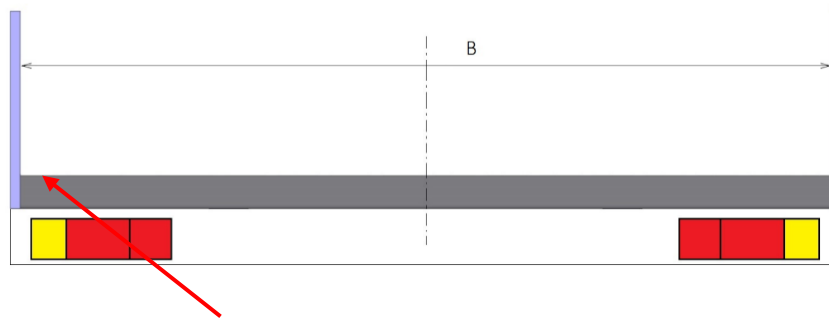

Start at the left side

The assembly of the floor will have to take place from the left to right.

Determining the Leak Proof subdeck length

FIG. 16

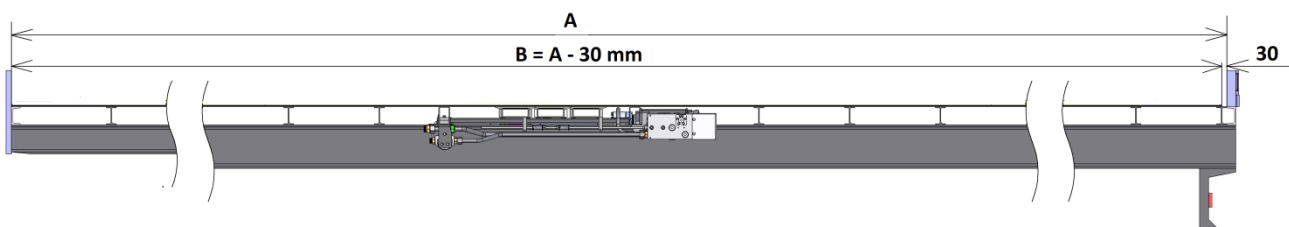

The length of the T-subdeck is determined by the space in the trailer. If possible the measurement from the inside of the head board till the inside of the doors will be leading. We call this measurement **A**. 30 mm [1.2"] will be deducted from this measurement in order to leave room free at the doors. This we call measurement **B**.



Attention: If you have anything protruding on the head board or on the doors at the height of the subdeck you need to take this into account with the determining of the length.

Cutting out the openings in the Leak Proof subdeck

At the place of the system parts will have to be cut out of the Leak Proof subdeck profiles through which the u-profiles will protrude.



Assembly of the floor should be done from left to right.
It therefore is extremely important to take care that the Leak Proof T-subdeck profiles are positioned in such a way that at the future rear side of the floor the convex is left of the driver side and the support lip is on the right.

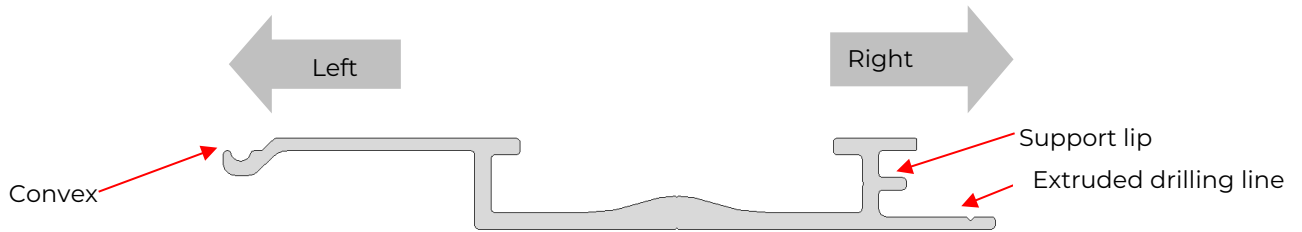

FIG. 17

Alu 8/160 mm Leak Proof T subdeck (Slide in) article no 871.5177

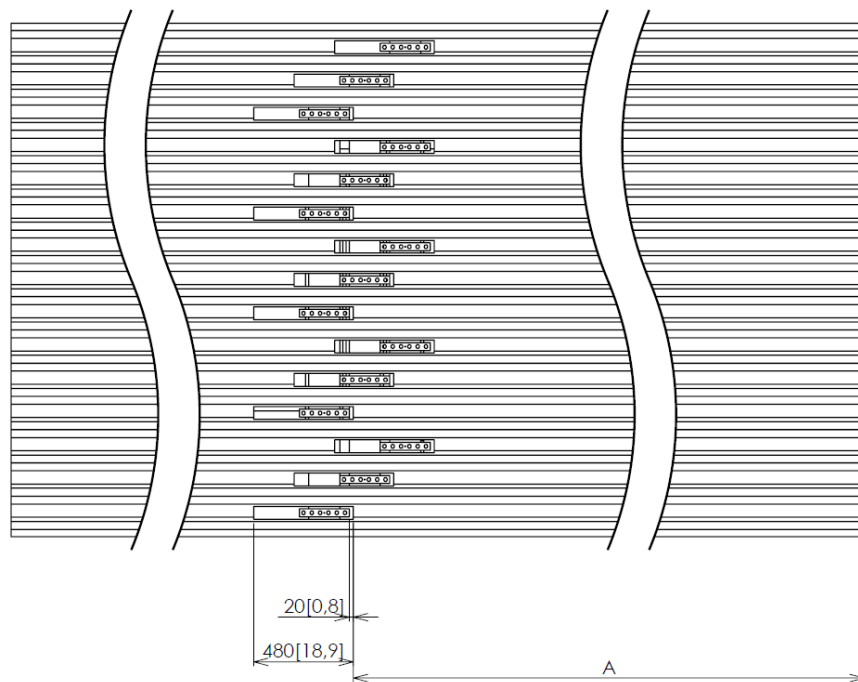

FIG. 18

The opening will be in total about 62 mm [2.4"] wide

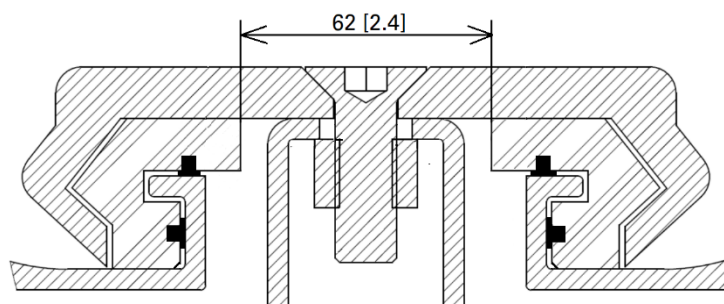
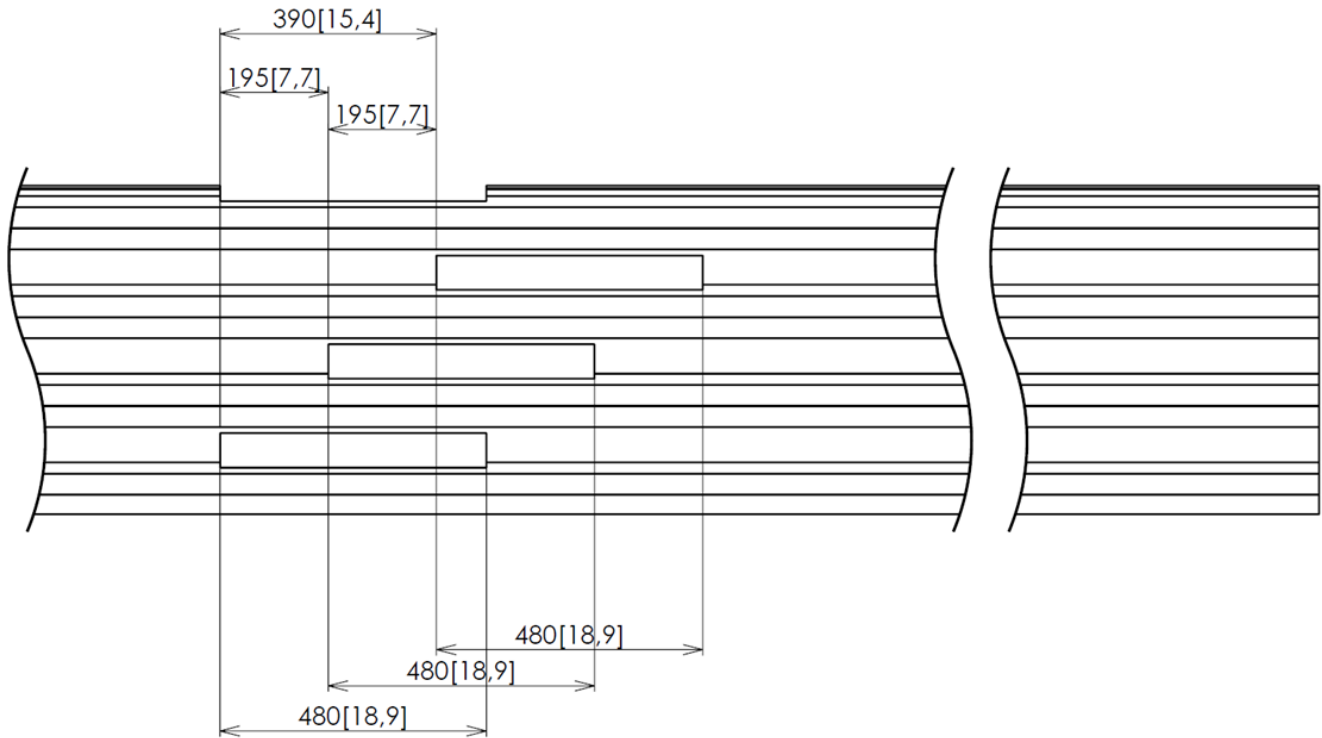
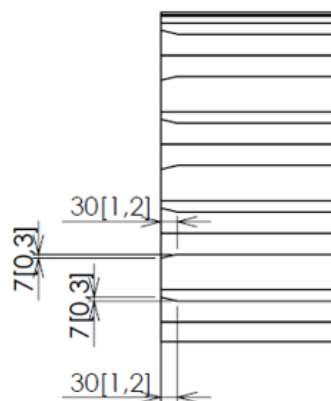

FIG. 19



For the position of these openings in the Leak Proof subdeck profile you can use the measurements in fig. 19. With the left **side** profile a cut away only needs to be made on the right side and with the right **side** profile a cut away only needs to be made on the left side. All the other profiles need a cut away on both sides. Position and length of the cut away are the same for every under profile.



In order to simplify the sealing or welding to the headboard at a later stage we advise to remove pieces of the T-shape at the head board side of the profiles (fig. 19).



Attention: after taking out the parts that were cut out of the profiles, the profiles will be weaker at this point, pay attention to [fig. 14](#) in order to prevent bending.

Determining the right width of the side profiles

Now the width of the **left** side profiles need to be determined. The method to do this is displayed in fig. 21 A. Pay attention to your under wall profile, this could possibly be an obstacle when determining the width, see fig. 20.



For the calculation it is important to determine beforehand if one will use sealant or weld the borders to the walls. The choice can affect the width of the seam to the wall. It is further important to realize that the seam between under floor and wall needs to be watertight. The method you pick is not determined by Hyva Floor.

FIG. 20

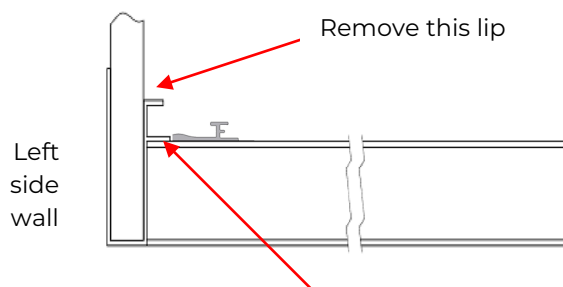

This lip needs to be taken into account with the width and the length of the subdeck profiles!!!

FIG. 21 A

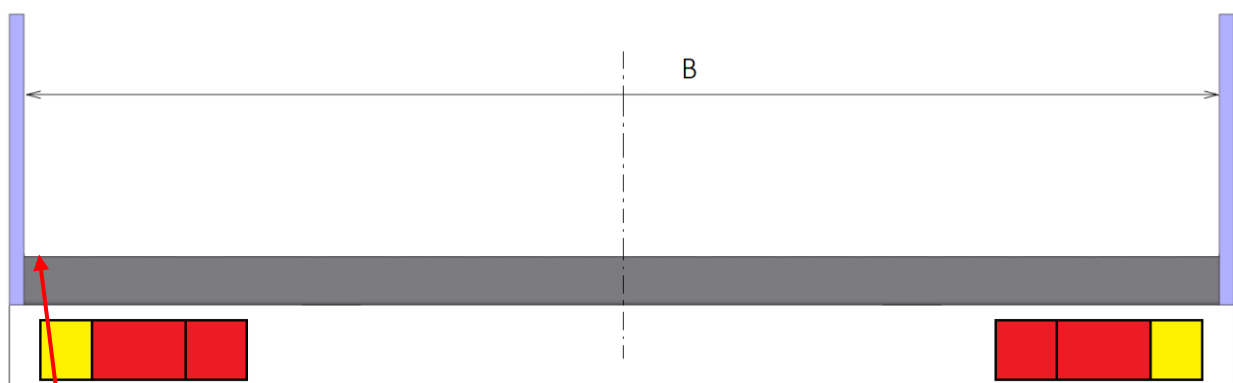

Start with mounting on the left side

FIG. 21 B

FIG. 21 C

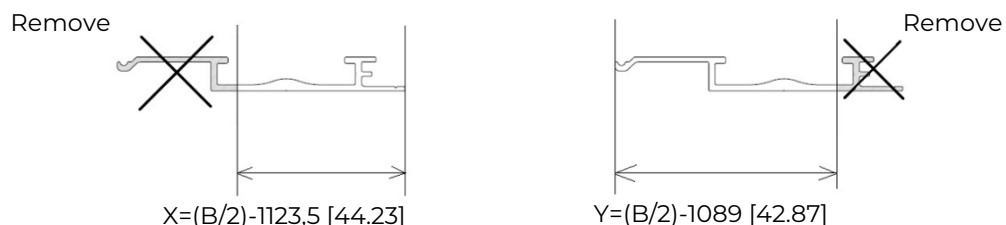

You divide the available room (pay attention to the obstacles and the chosen seam width) between the walls by two and deduct for the left profile 1123,5 mm [44.23"] from this value. The value that remains is the width of the left side profile.

The best thing to do with determining the width of the right side profile is to do this after mounting all the other floor parts. By doing this you prevent that the actual size is different from the theoretical due to the application of various tolerances. We did however put a theoretical measurement in fig. 21 C.

Placing and mounting the first under floor profile

The first profile that needs to be mounted is the lengthwise sawed through side profile. These should be mounted at the 1123,5 mm [44.23"] measurement from the centre line of the trailer. Do check this measurement very meticulously at various places before fixating the profile. If this profile is not positioned properly it will affect all the other profiles as well.

FIG. 22

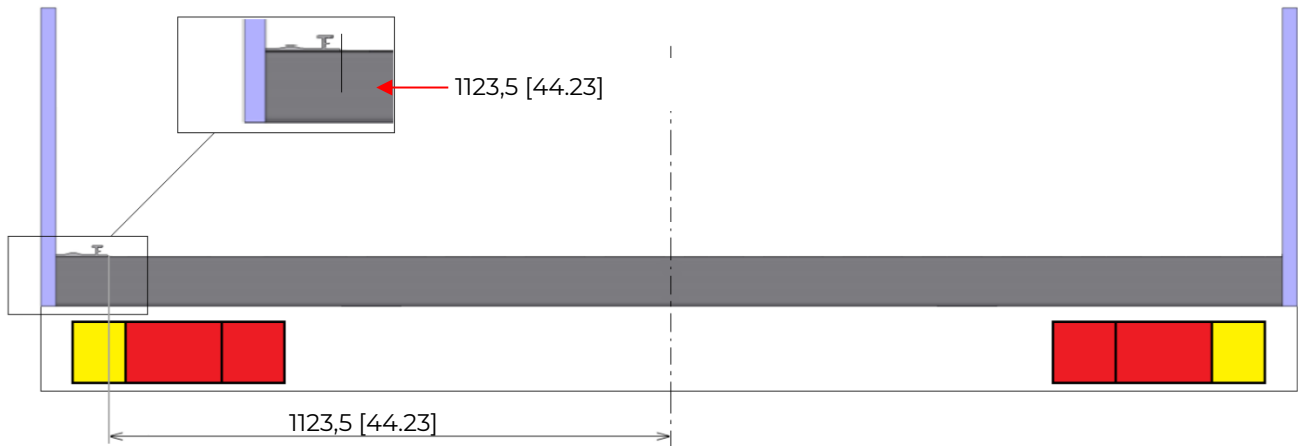

After placing the side profile it can be fixated. In order to prevent moving of the profile during fastening you can fixate the profile temporarily at several places by using glue clamps.

Now you can fasten the side profile to the cross members. You can do this with self-drilling bolts, mono bolts, nails for a nail gun or welding (see fig. 23). Ask your supplier of fastening materials for advice of possible alternatives. We do not advice rivets fully made of aluminium, these are not strong enough. Only rivets with a steel core are suitable (so called mono bolts).

In the profile a drilling line has been extruded so you easily can determine the centre of the hole that needs to be drilled. Fasten the profile to every cross member.

Welding the profile needs to be done with a weld with a length of minimal 30 mm [1.2"] and with an a=3.



The fixation of these under profiles will be under greater strain as the chassis is more flexible. Please take this into account when fastening.

FIG. 23

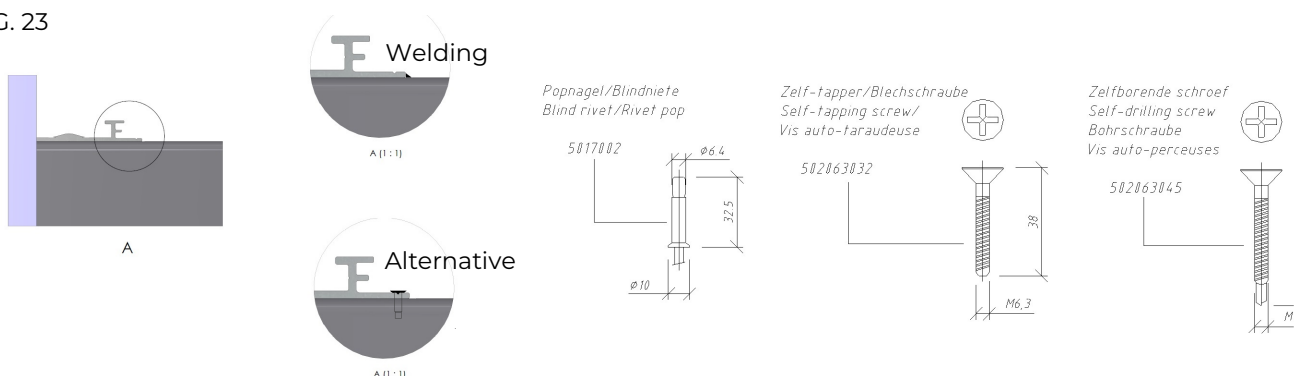

Check after fixation of this profile the measurement to the centre of the trailer again. The position of this profile is very important because is the reference for all the other under floor profiles. Now the other profiles can be mounted.

Secure the other under floor profiles

The next under floor profile can now be mounted with the convex in the support lip as shown in fig. 25. There are 2 methods to connect the under floor profiles to each other: with sealant or welding.

Method 1: sealant

Apply sealant on the support lip (fig. 24 A) of the floor profile that already has been mounted and the convex of the profile that needs to be mounted (fig. 24 B). The sealant should come well above the cavity of the convex (about 5 mm) and is applied over the full length of the floor profile, except the first 50 mm [2"] on the head board side and the last 50 mm [2"] at the door side (fig. 25, the first and last 50 mm [2"] will be welded shut). A sealant you could use is Sika 252. Please follow the instructions (for pre-liminary treatment/preparations and in which situations it can be used) given by the supplier/maker for the sealant you choose carefully. About 400 ml sealant per under floor profile will be needed.



Attention!

Always keep the working time of the sealant in mind.

After this the two profiles can be slid into each other, it could be that you need to use clamps to get the two profiles to go towards each other. Check if the profile is placed correctly with the help of the three positioning jigs (parts no. 9111205). With these jigs one can, at various places, check if the convex and the support lip have gone correctly into each other (fig. 26 and 27).

When this profile is placed correctly, it also can be fastened to the cross members. You can do this with self-drilling bolts, mono bolts, nails for a nail gun or welding (see fig. 23). Level of the protruding sealant and there where necessary fill up the top V groove so it is fully filled.

After you have fastened all the under floor profiles to the cross members you can weld the 50 mm on the front and back side shut. The weld may not protrude the top surface of the slide in profile because of the bearing that still needs to be mounted (see fig. 28). If the weld does protrude it needs to be ground of and finished smoothly. After welding and smoothing you need to check all welds and fill seams/holes between sealant and weld with sealant so the floor is fully sealed off (here to level off protruding sealant).

FIG 24 A

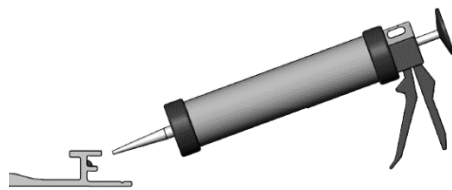

FIG 24 B

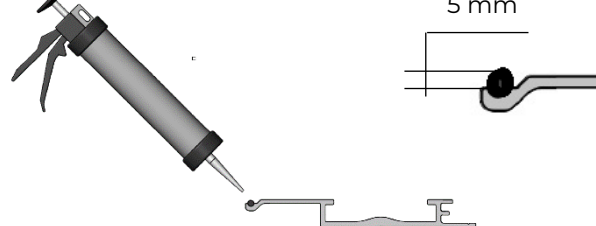

FIG 25

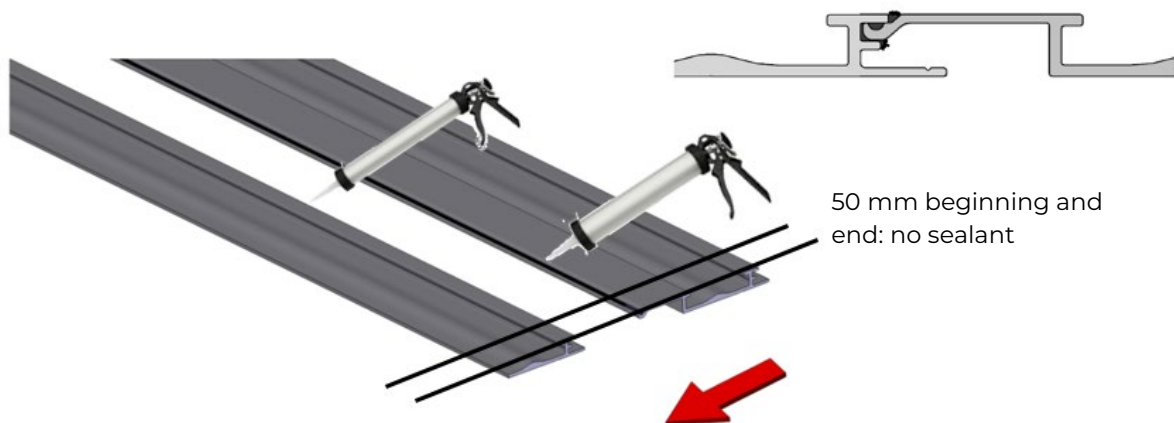

FIG. 26

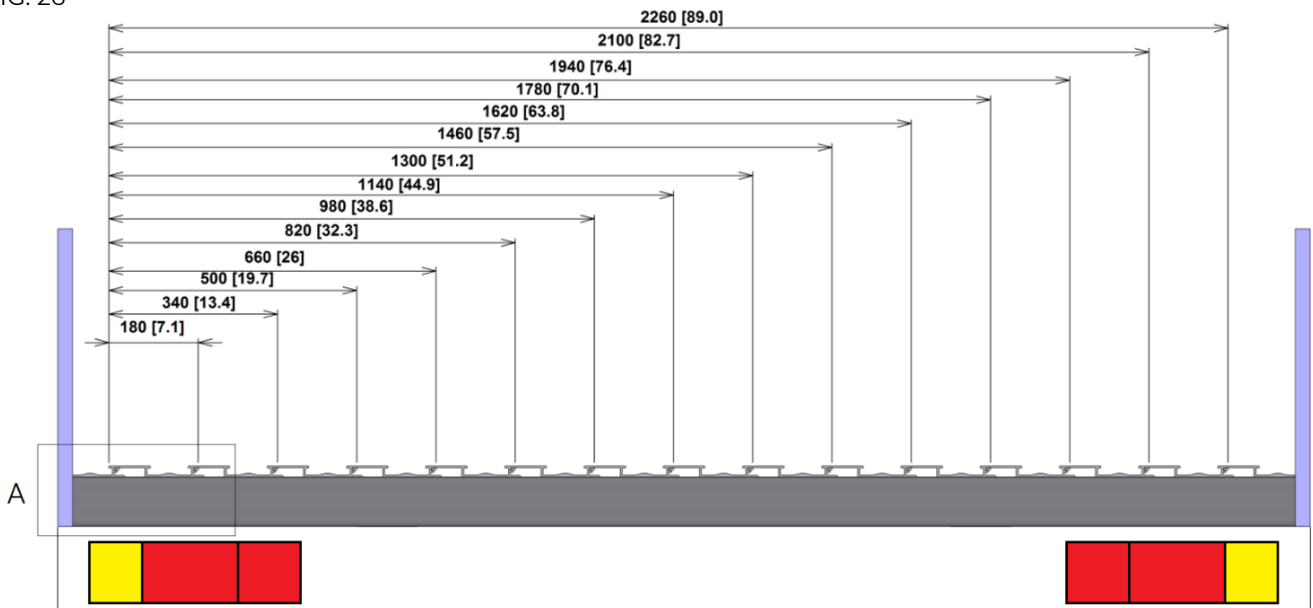
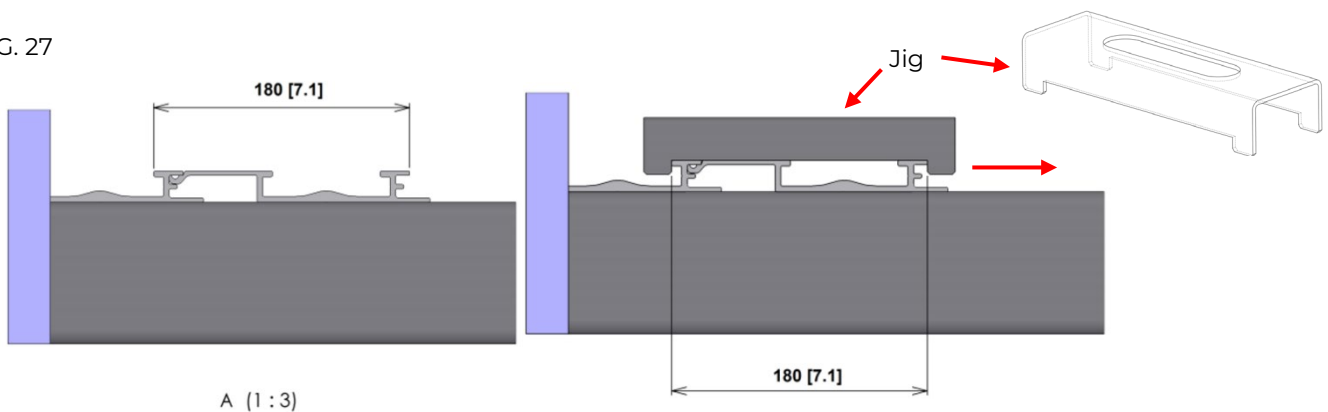

FIG. 27



Attention!

Do not use sealant when choosing to weld the profiles, gases could form, causing the weld to leak.

Slide the next under floor profile in its position. Check the measurements (fig. 26 and 27) and fasten it to the cross members. When this profile is placed correctly, it also can be fastened to the cross members. You can do this with self-drilling bolts, mono bolts, nails for a nail gun or welding (see fig. 23).

Now weld the whole v groove shut over the full length.

The weld may not protrude the top surface of the slide in profile because of the bearing that still needs to be mounted (see fig. 28). If the weld does protrude it needs to be ground off and finished smoothly.

FIG. 28

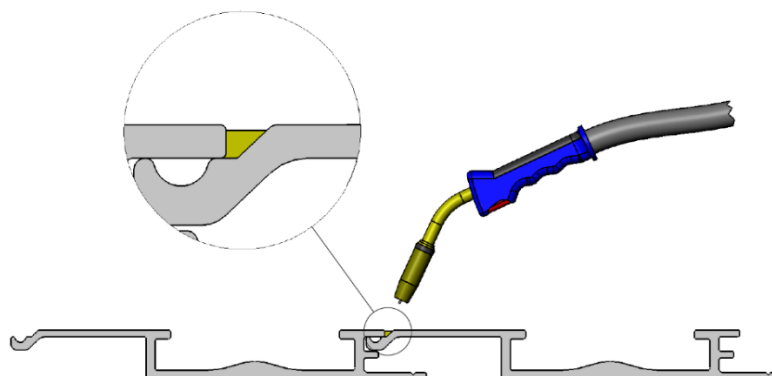

Finishing the edges of the under floor

When the complete mounting of the under floor has been done one needs to take care of making a watertight connection all around the floor between the under floor and the other components of the trailer. All seams and openings need to be closed by using sealant or welded shut.



You start at the rear side by welding a plate (measurements aluminium plate 60x20x3 [2.35"x0.8"x0.12"]) over the opening of the T-shape as mentioned in fig. 29 A. The weld may not stick out of the T-shape.

FIG. 29 A

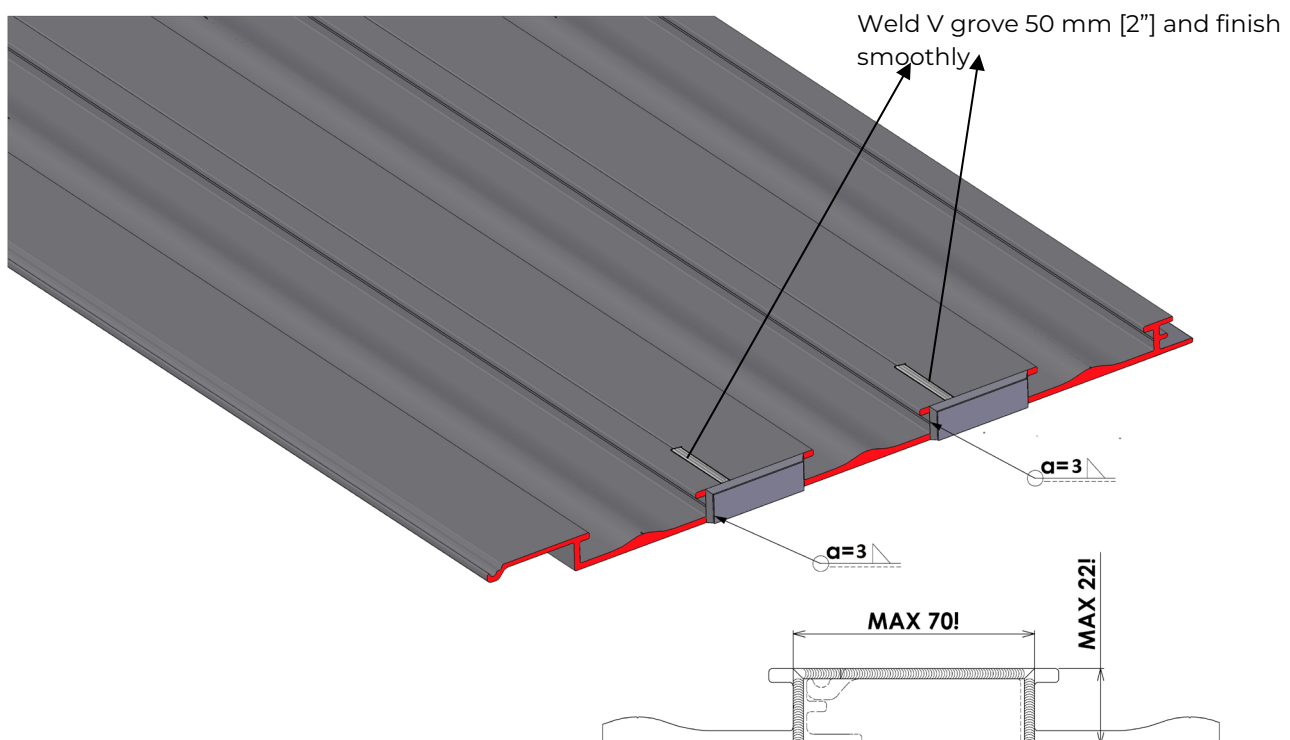

After the sealing of the T-Profile the complete rear seam can be welded or sealed from the under floor to the rear beam (fig. 29 B).

FIG. 29 B

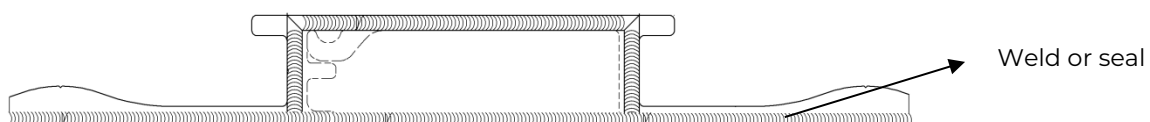

40 TON FLOOR LEAK RESISTANCE ASSEMBLY INSTRUCTIONS

At the head board side the under floor can be welded or sealed by following the outline (fig. 29 C).

FIG. 29 C

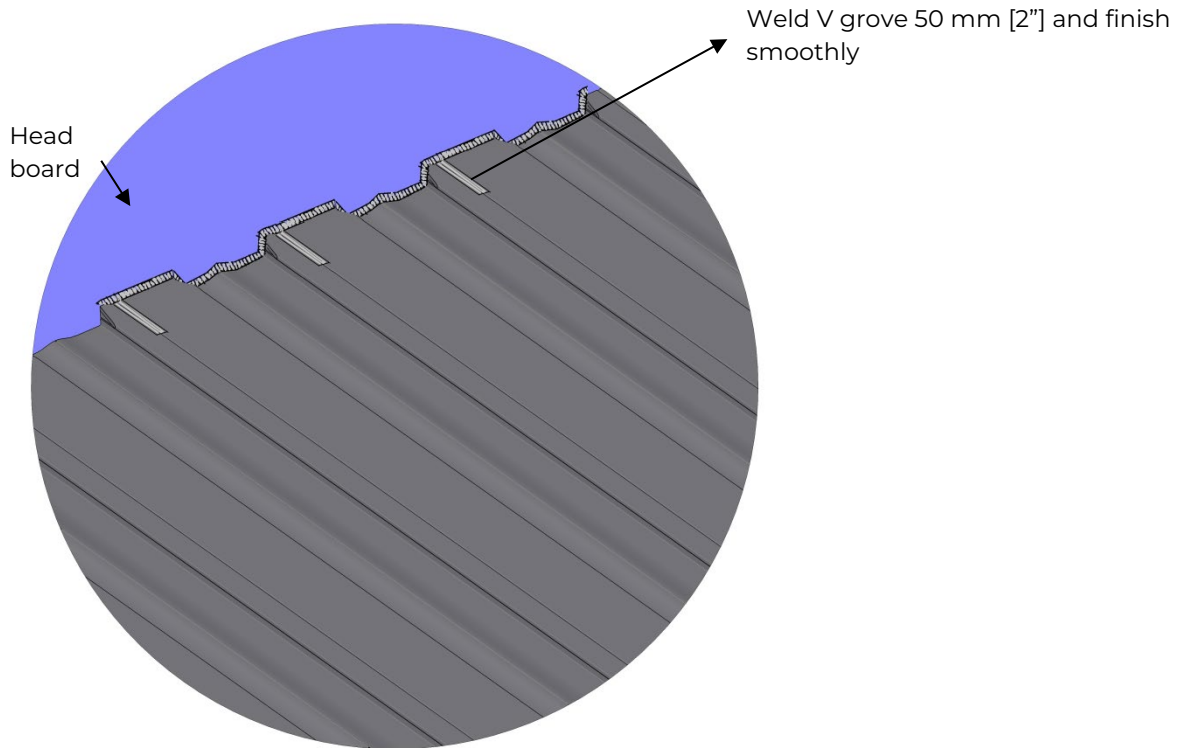

Now the seam between the side profiles and the walls can be sealed or welded. After sealing all around all the under floor profiles the seam on top of the convex needs to be checked if the is sealing sufficiently. It could be possible that at a number of places the seam needs to be sealed further (fig. 30).

FIG. 30

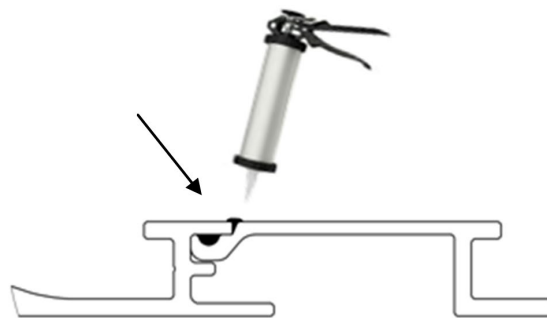

Mounting the plastic bearing profiles

Mount end stops

After mounting and finishing the aluminium T-subdeck floor a start can be made with the assembly of the plastic bearing profiles and the aluminium end stops T-subdeck LP floor (350 mm [13.8"], art. no. 5448006). The aluminium end stops are mounted at the headboard side and the door side. First an aluminium end stop of 350 mm [13.8"] is mounted near the headboard, this end stop is fully pushed to the front until 30 mm [1.2"] in front the headboard. Because of this there will be room to weld it to the under floor. The end stop at the headboard side needs to be welded to the T-subdeck with a weld a=6 (fig. 31).

FIG. 31

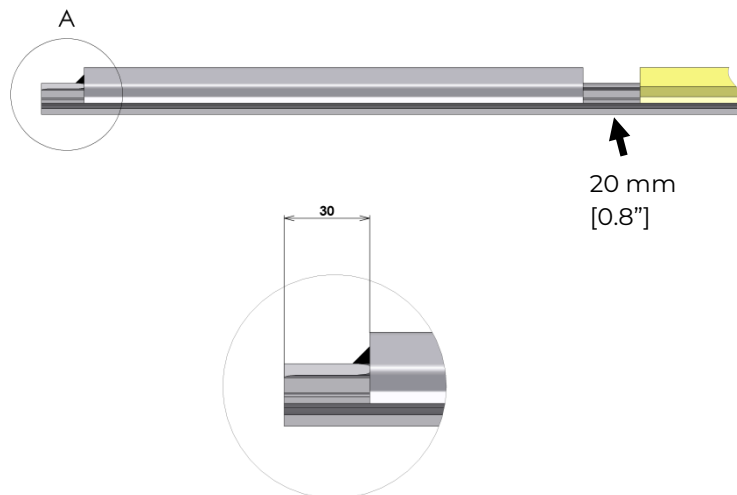

Mount plastic profiled solid sealing profile

At the U-profile for moving cross member the plastic profiled solid sealing profile for T-subdeck, LR-series, art. no. 4107045 needs to be mounted, fig. 32A1 and B. Put sealant in the length grooves before mounting, then mount both sealing profiles at the right spot.



Attention!

Press them together as best as you can so the width is ≤ 114 mm [4.5"] and the floor profile fits over it.

FIG. 32 A1

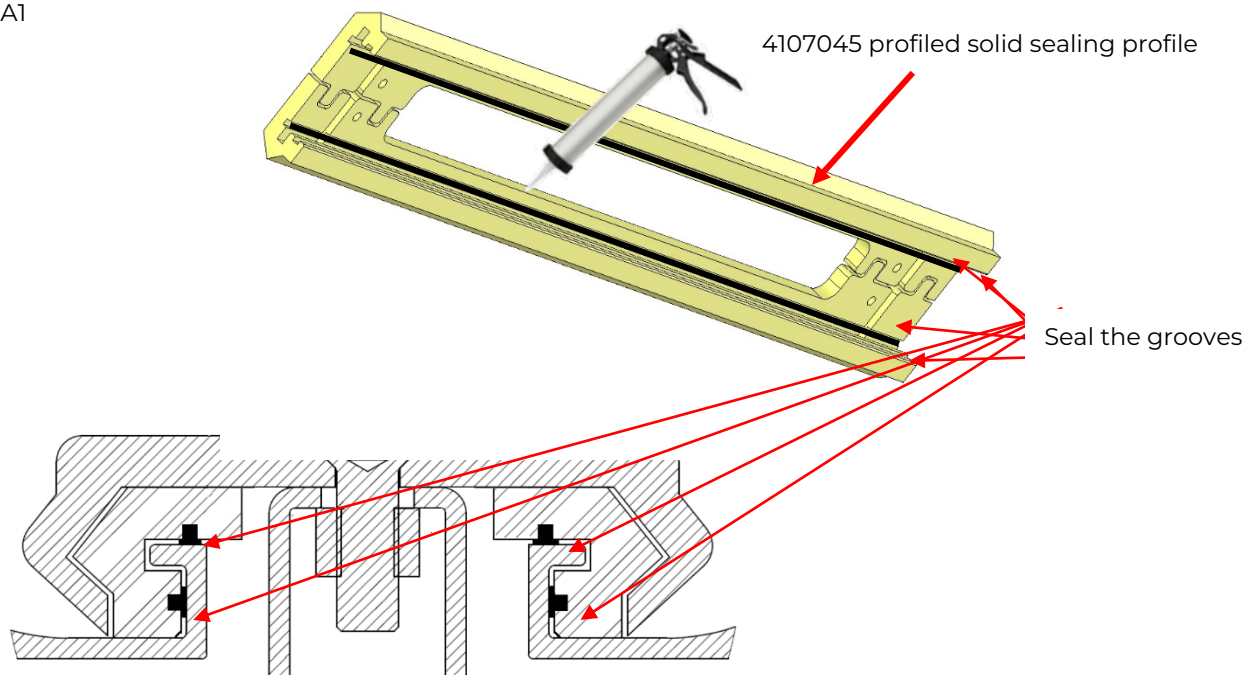

Now drill the 4 holes for the mono bolt round pan head 6.4x24.6 through the T-subdeck and fasten the sealing profile with the bolts. Put sealant in the width grooves and on the front left and rights side (fig. 32 A2)

FIG. 32 A2

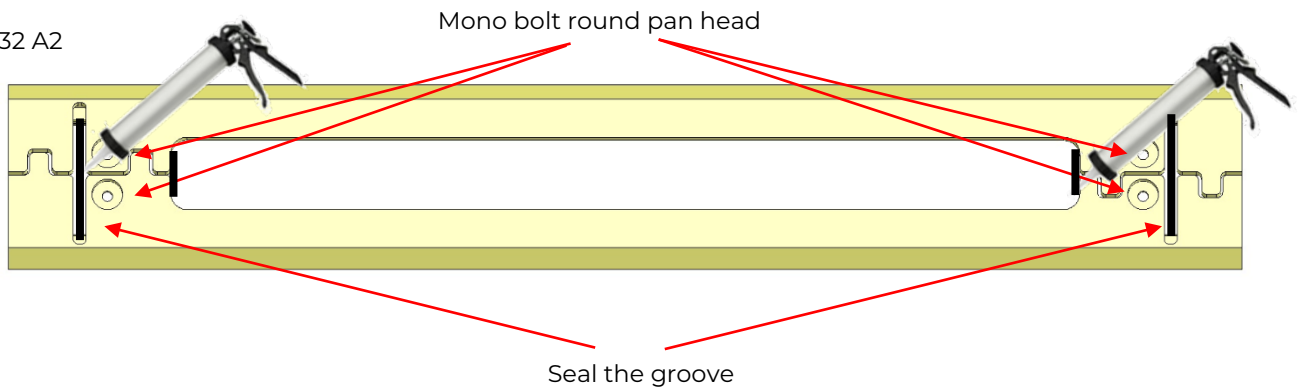

Mount plastic bearing strip solid, type A and B

Fill the whole length of the T-subdeck with plastic bearing profiles: from head board to the sealing profile and the sealing profile to the door. Keep in mind that at the head board and doorside 20 mm [0.8"] space remains open.

Click plastic bearing strip solid, type A (art. no. 4107022.01) and plastic bearing strip solid, type B (art. no. 4107022.02) simply in each other over the T-profile of the subdeck.

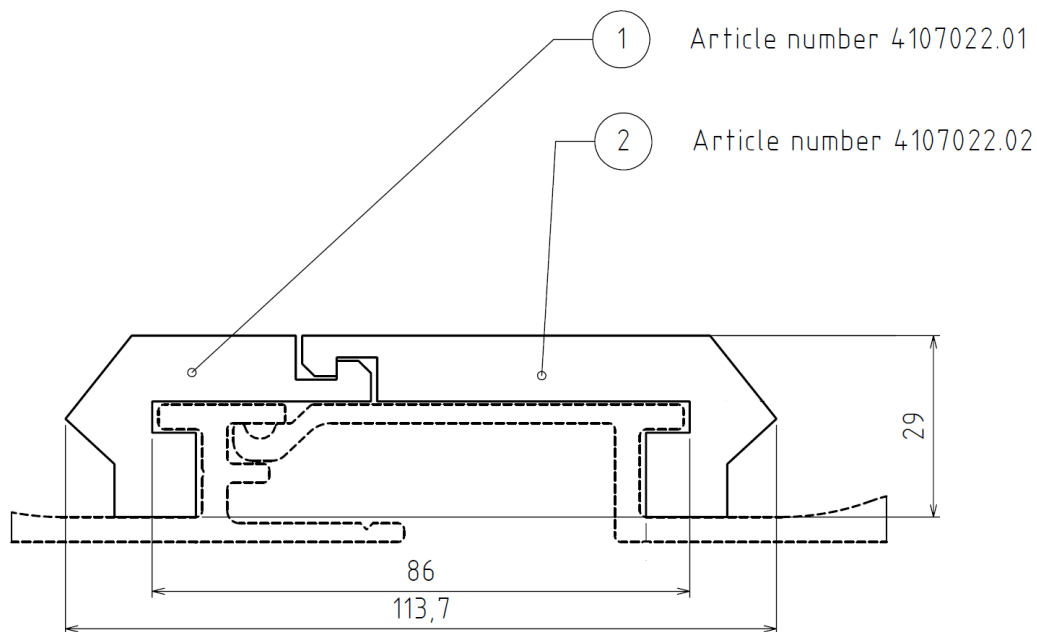

Attention

On head board and door side a space of 20 mm [0.8"], between end stop and plastic bearing profile, should remain open.

FIG. 32 B

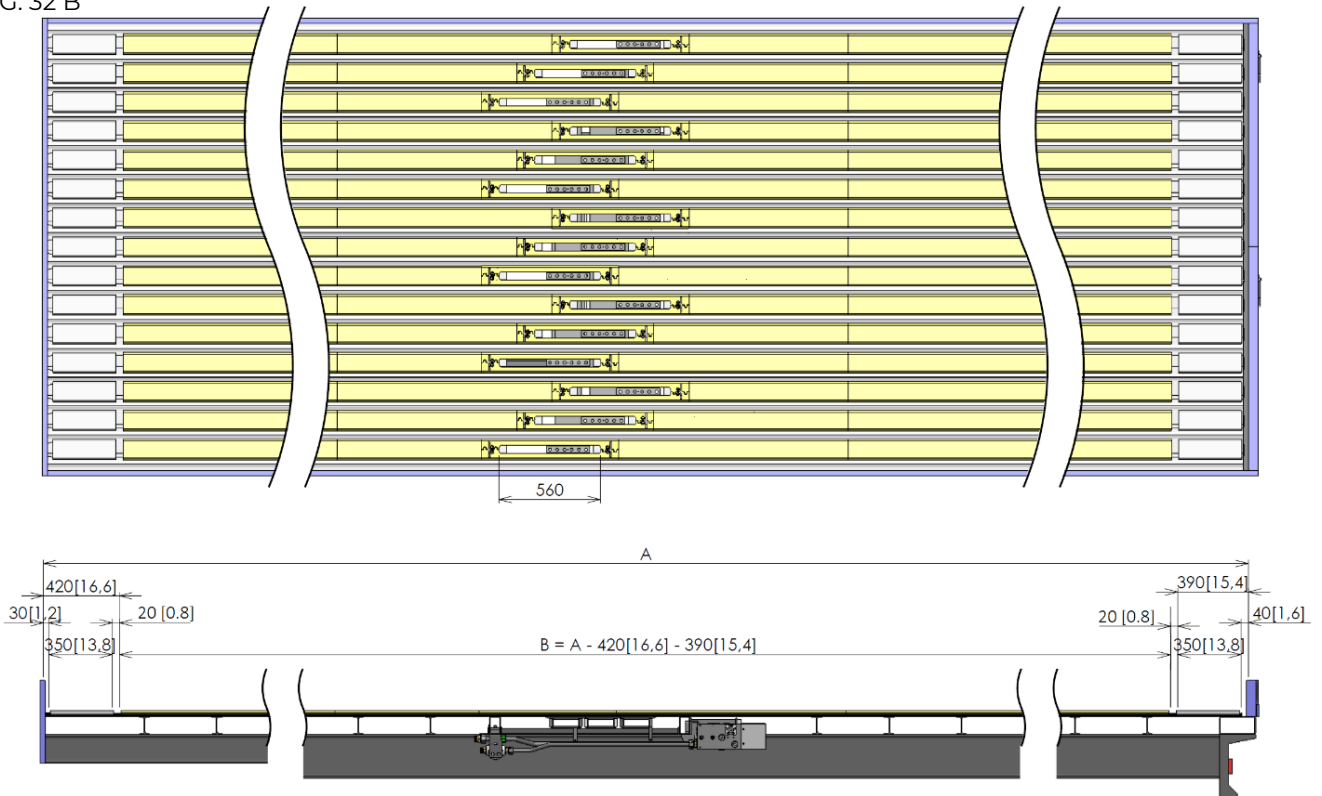

The plastic will be closed in at the door side by an aluminium end block that needs to be welded with a wide weld at the top side of the T of the T-subdeck floor. **The aluminium end block is placed 10 mm [0.4"] from the end of the T-subdeck floor (fig. 33 B).**

FIG. 33 A

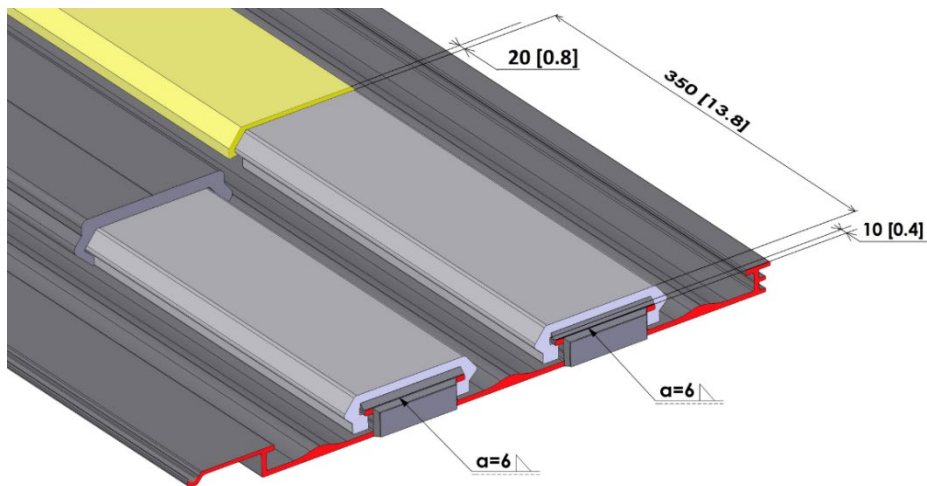
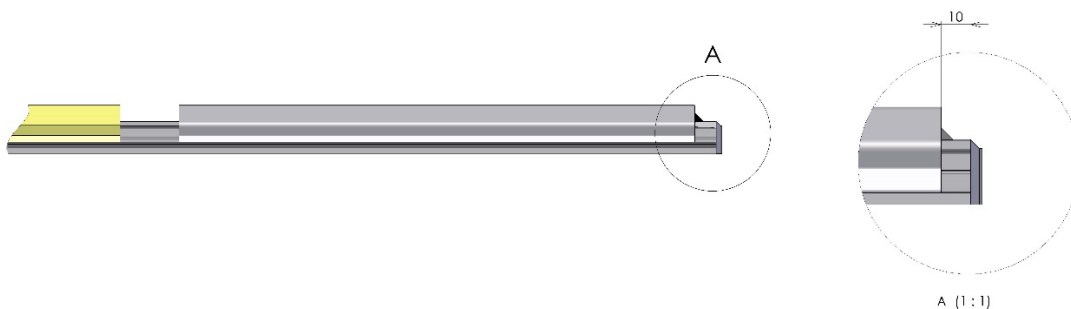

FIG. 33 B



Determining the length of the top profile

When calculating the length of the Leak proof deck slat floor profile you need to use the following calculation. You measure again the inner length of the trailer (length A). Deduct the stroke length of the cylinders (-200 mm [7.9"]). Next to this a space of 100 mm [3.9"] in the direction of the head board must be kept clear (in order to prevent material getting squeezed). The space to the doors needs to be 40 mm [1.6"]
 This results in the following equation: $A - 200 - 100 - 40 = A - 340$ mm [$A - 7.9'' - 3.9'' - 1.6'' = A - 13.4''$]

FIG. 34

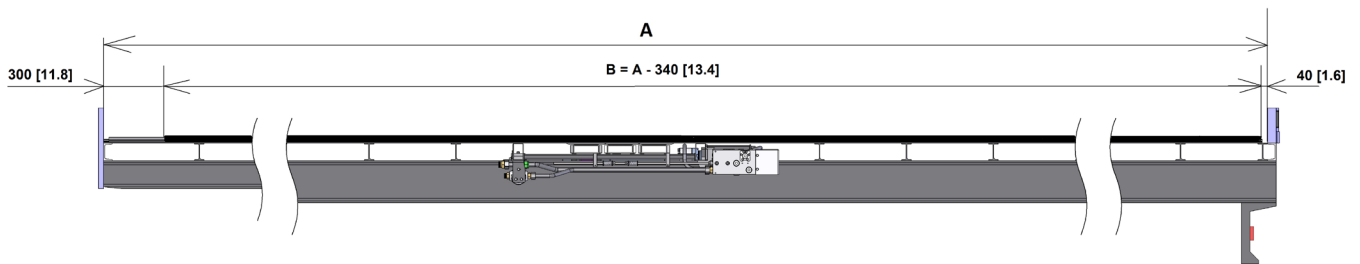

Before the deckslat profiles are mounted into the trailer these will have to be rounded-off (beveled) at the head board side (fig. 35).

FIG. 35

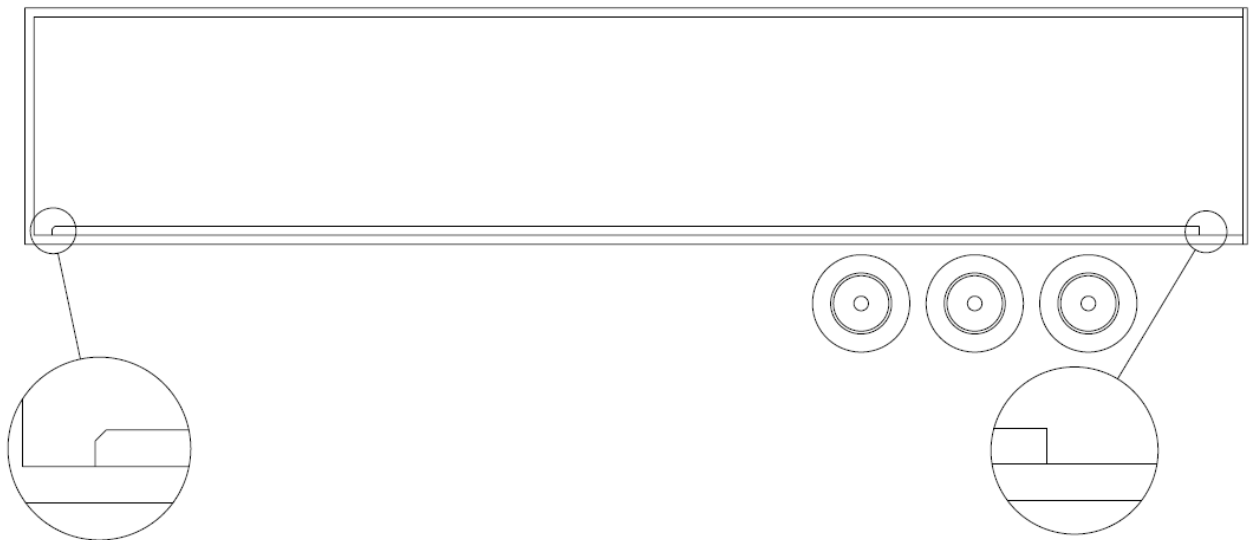

**Alleen deze zijde
 Only this side
 Nur diese Seite**

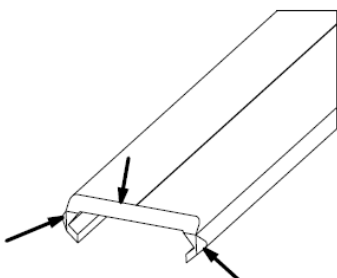

Transfer execution

We are talking about a transfer execution if the trailer is built in such a way that the trailer is loaded at the same place (usually the rear side) and the load is distributed over the full length of the trailer (to the front) using the Hyva Floor system.

With this there are a number of differences with regards to the regular transport which should be taken into account: loading with the doors closed, longer switching on of the system, the loading function is used more often, pushing against the head board with possible an application with an electro hydraulic unit and multiple loads / unloads per day.

When mounting the system to the chassis long term and changing large forces should be taken into account. Also a strengthened headboard needs to be used where the load is pushed against.

Mount wedges at the inside of the doors, so the load does not get in-between the end of the profiles and the door and the material does not get compacted. The profiles should remain under the wedges of the doors in the stroke (fig. 36 A).

Alternatively, the wedge can be omitted, but then the following guideline needs to be executed:

The profiles need to be bevelled at the rear as well as the front side. If no wedged is used at the door side the profiles also need to be shortened with 100 mm [3.9"] at the door side, identical to the head board side (fig. 36 B). If a running head board is present, the tarpaulin needs be hung before the loading starts. The head board in this case cannot be used.

FIG. 36 A

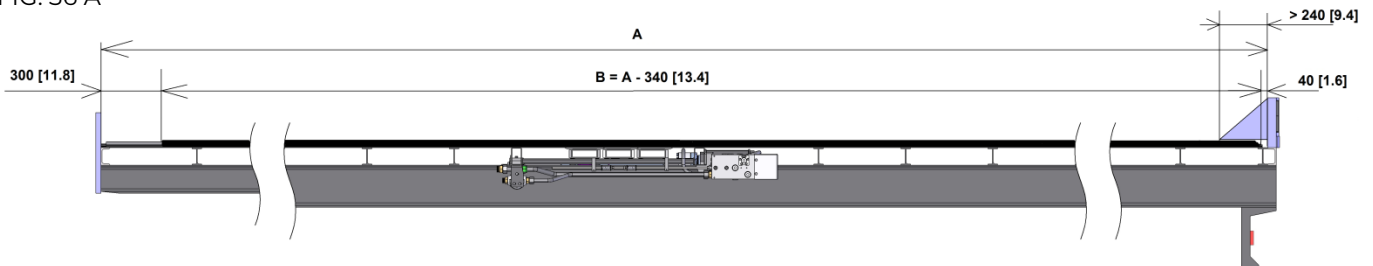
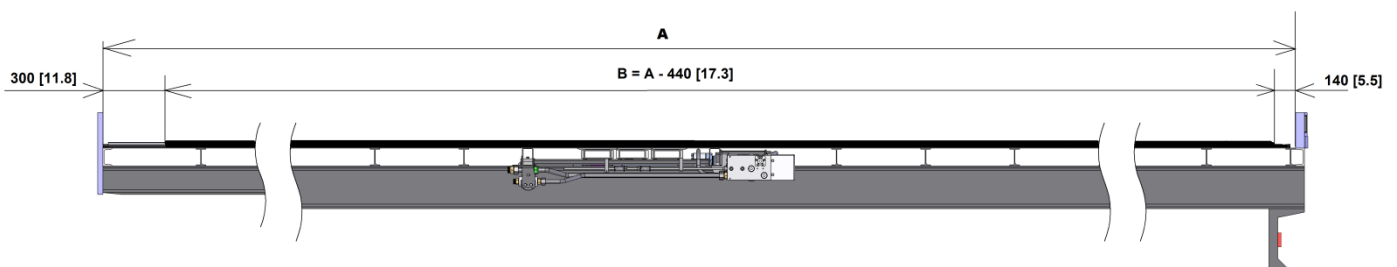

FIG.36 B



Attention!!! With specific or exceptional use a larger oil supply needs to be present than the normally advised 150 litre [39.6 US gallon].

Other points of attention with regard to the system are:

- Use HD cylinders and massive rod bearing;
- Brace the system and fasten it extra;
- Mount the profiles with 6 screws.

Drill mounting holes in the profiles

The profiles need to be fastened with **6 bolts**.

FIG. 37 A

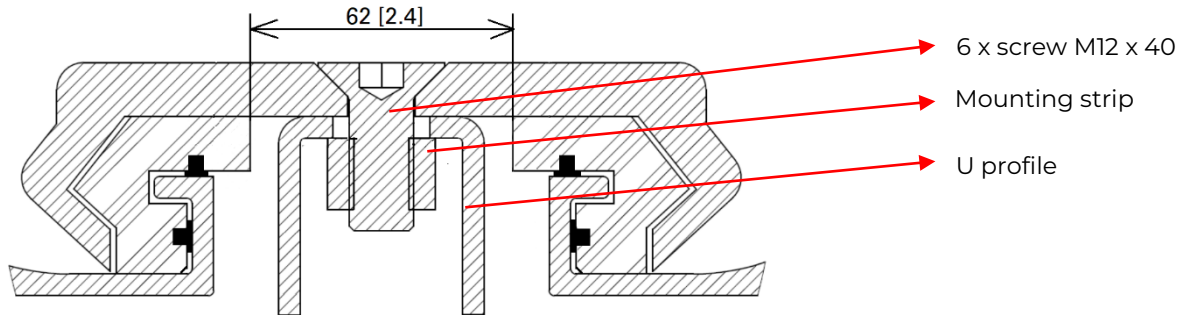

First you need to determine the holes in the profiles, see fig. 37.

Check if all the cylinder are completely pulled in. You can check this as following: the piston rods may not protrude more than 5-10 mm [0.20-0.39"] out of the plastic bearing block.

The position is determined by measuring from the inside of the door till the first hole of the u-profiles for the third group. Deduct this measurement with 40 mm [1.6"] and you have determined measurement A. Mark on the 5 profiles of the third group the spot of this first hole on the top side of the profile.

The five profiles of group 3 will have the hole patten on distance A.

The five profiles of group 2 will have the measurment A + 195 mm [7.7"]

The five profiles of group 1 will have measurement A + 390 mm [15.4"]

FIG. 37 B

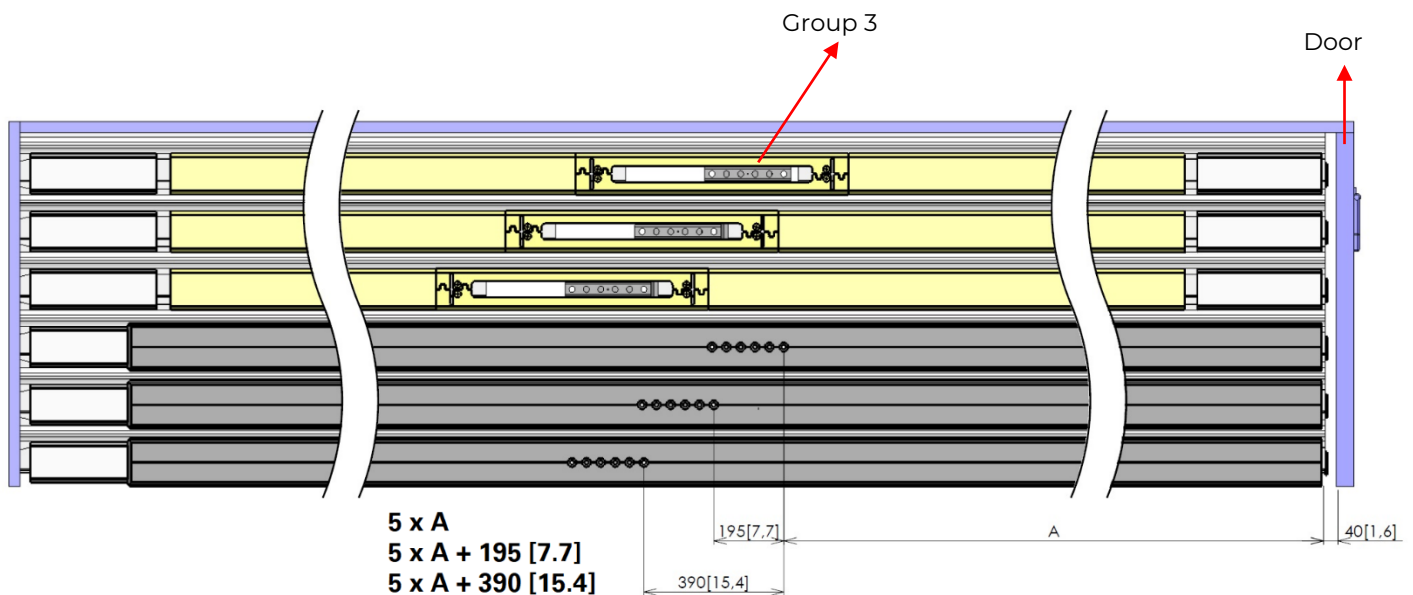

Cylinders should be fully pulled in

Drilling the holes in the floor profiles

The holes in the floor parts need to be drilled before these are placed. One needs to pay attention to the fact that the holes must be drilled staggered due to the differing distances of the moving frame feet in the drive system (see figure 37).

- Drill 6 holes of $\varnothing 4.5$ mm [0.18"] with the aid of the drill jig (fig. 38) on the top side of the floor profile ensuring the centre of the holes line up with the reference line. Then bore out the holes, from the same direction, to about $\varnothing 12.5$ mm [0.5"]
- Next the holes need to be countersunk from the top side using a good countersink bit according to the specification G136 HSS DIN 335 C, code 13628.0 (figure 39) Make sure that the hole is countersunk to the right depth; the bolt head must not stick out above or under the floor profile. See figure 40.

FIG. 38 FIG. 39

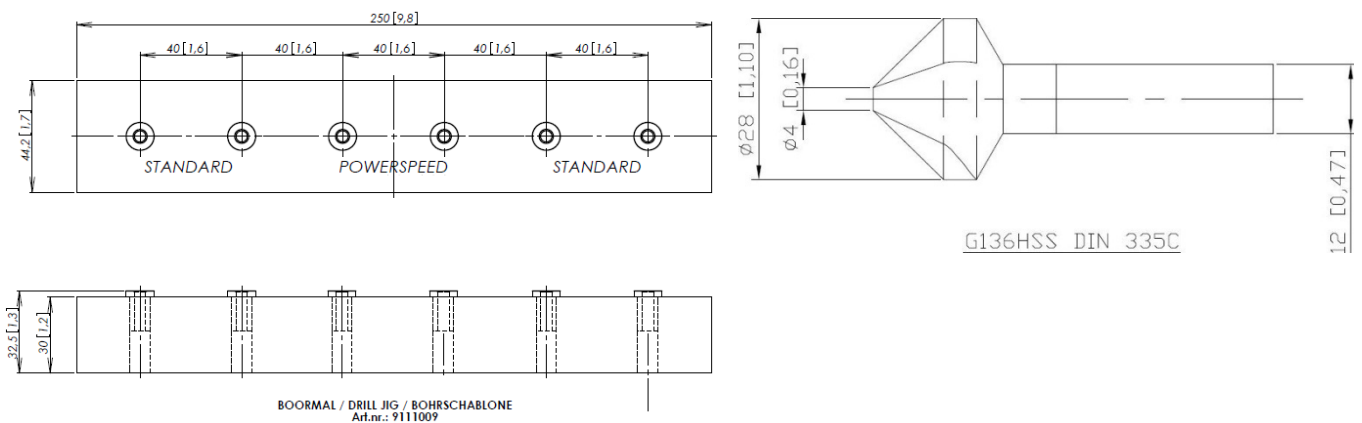
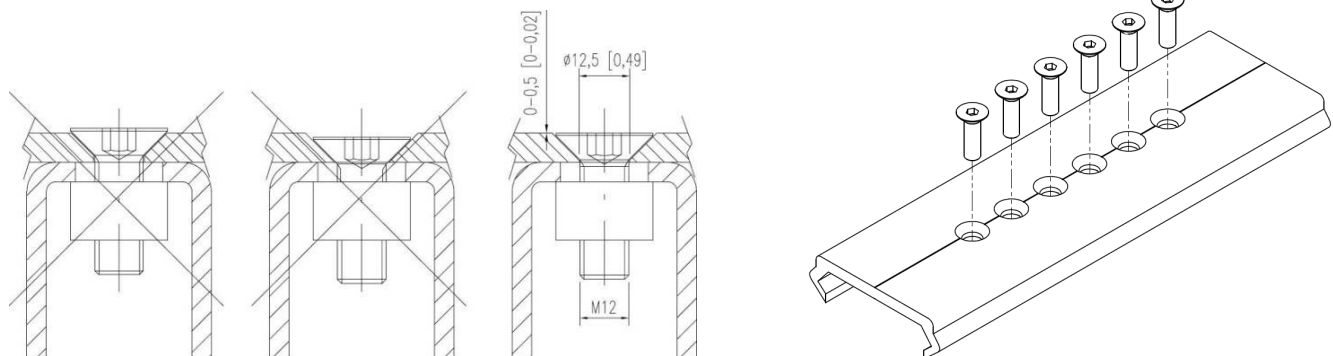

FIG. 40

FIG. 41



Securing the floor profiles to the drive unit

After this the profiles can be slid over the plastic bearing. You need to carefully guide the floor profiles during the mounting procedure. Next, mount the provided hexagon socket countersunk head screw M12 x 40 (art.no. 502112040.2) using Allen no. 8. Each profile needs to be fastened with 6 bolts. The torque is 100 - 140 Nm [72-105 lbf.ft.]. One person can do this from above, and the bolts need to be well tightened.



Every bolt should be fitted with Loctite (Loctite 243 cat.o. 23286 screw thread locker).

Mounting the control box and the electrics

The control box can simply be mounted, without drilling holes, to your own mounting construction or on the mounting bracket that can be supplied as an option. This mounting bracket can, depending on the shape of the cross members, be mounted without drilling holes with the supplied clamping plates. The mounting bracket has three heights for mounting the control box. Also the, optional, wireless remote control RX/TX can simply be mounted into the control box, with the E-control as well as the B-control.

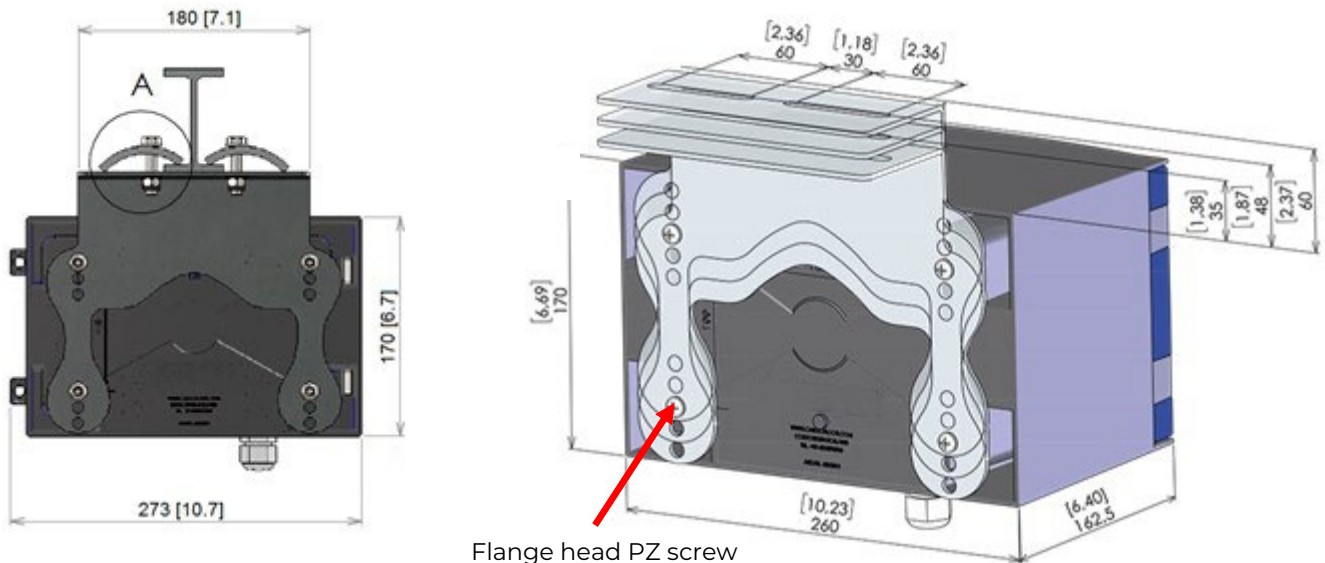

Flange head PZ screw for plastic, 6x20 mm

E-control

With the E-control the controlbox HF7 is provided with 3 electrical cables:

- 1x 2 core connection cable for the power supply. The brown cable needs to be connected to the 24V+ and the bleu cable to the 24V-.
- 1x 2 core cable with premounted black plug Deutsch for solenoid GS02 on/off;
- 1x 2 core cable with premounted grey plug Deutsch for solenoid G02 unloading/loading;



B-control

With the B-control the control box HF3 is provided with 3 electrical cables:

- 1x 2 core connection cable for the power supply. The brown cable needs to be connected to the 24V+ and the bleu cable to the 24V-.
- 1x 2 core cable with pre-mounted black plug Deutsch for solenoid GS02 on/off;
- 1x 2 core cable with pre-mounted grey plug Deutsch G02 equipped with a watertight end cap and sticker "do not cut".

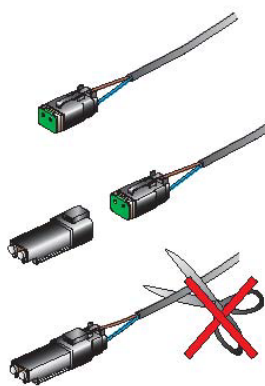

GS02 on/off plug black

Mount to cable G02

It is important that the watertight plugged cable with plug is mounted, but not can nor needs to be connected. This cable and plug need to be fastened somewhere near the control valve. The mounted watertight plug may not be removed.

The moving headboard

The moving headboard can be made from sidewall profiles reinforced by an edge profile. It is also possible to use a frame with a tarpaulin as a moving headboard. It is the best to hang the headboard on two Cargo Rollers, Heavy Duty, 6 wheels with bi-directional cleaning device in the rails (part no. 5165003), see figure 31A, mounted on the top edge of the trailer. Many aluminium top edges have this rail already integrated.

Mount the rails at the same width as the width of the trailer. The moving headboard needs to be fastened to the Cargo Roller with at least 3 chains links and make sure the hanging point of the headboard is directly beneath the roller so that the headboard can move freely and the Cargo Rollers won't jam. Let the moving headboard run free on both sides of the side walls, about 25-30 mm [1"-1.25"]. Brushes or rubber flaps can be mounted between the headboard and the sidewalls to avoid leakage and to keep the sidewalls clean. The sidewalls of the trailer need to be smooth so the headboard cannot get stuck on something.

FIG. 31 A

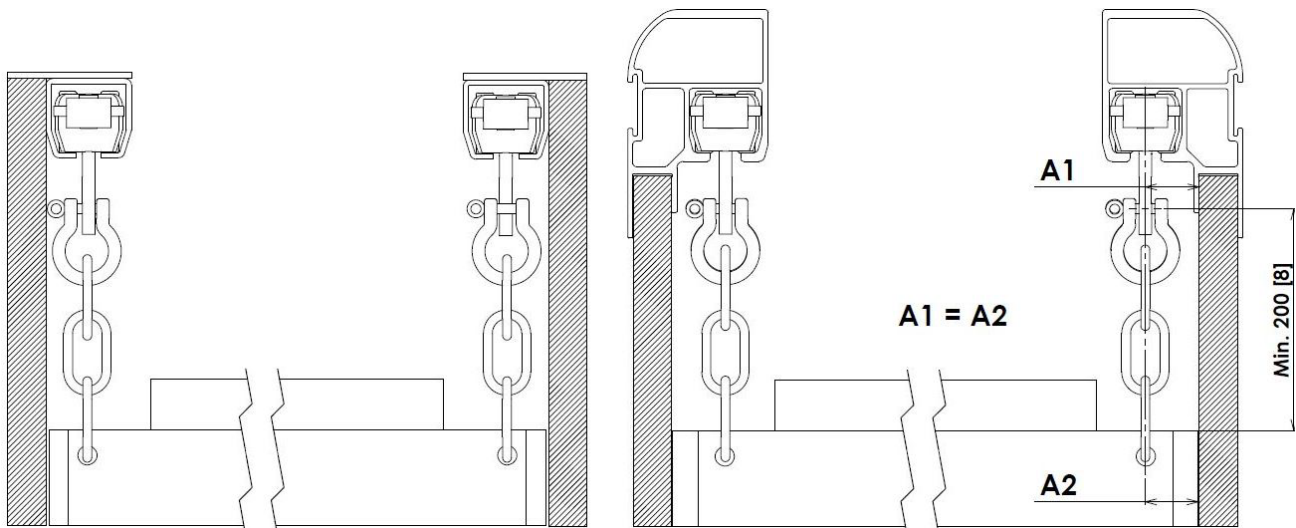
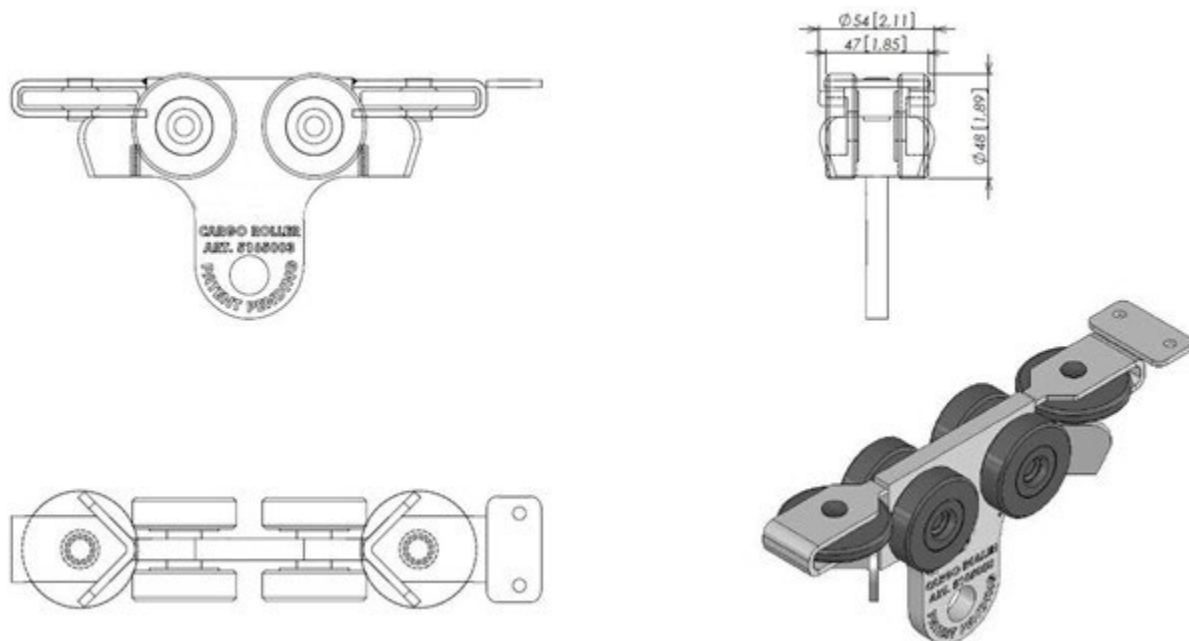

FIG. 31 B

Cargo Roller, Heavy Duty, 6 wheels with bi-directional cleaning device (part no. 5165003)



The moving headboard tarpaulin

In order to allow the headboard to move with the load, a tarpaulin is fastened to the underside of the moving headboard, see figure 32. A section of this tarpaulin (about 1.250 mm [4"]) needs to lie on the floor. This section of the tarpaulin needs to be fitted with one or more pine (wood) planks. The planks are in loops of the headboard tarpaulin of the tarpaulin is clamped between these planks. The fastening bolts/screws need to be well countersunk so as to ensure that they do not come in contact with the moving floor.



Attention!

These planks are about 20 mm. [0.79"] shorter than the smallest internal width of the loading space of the container.

FIG. 32

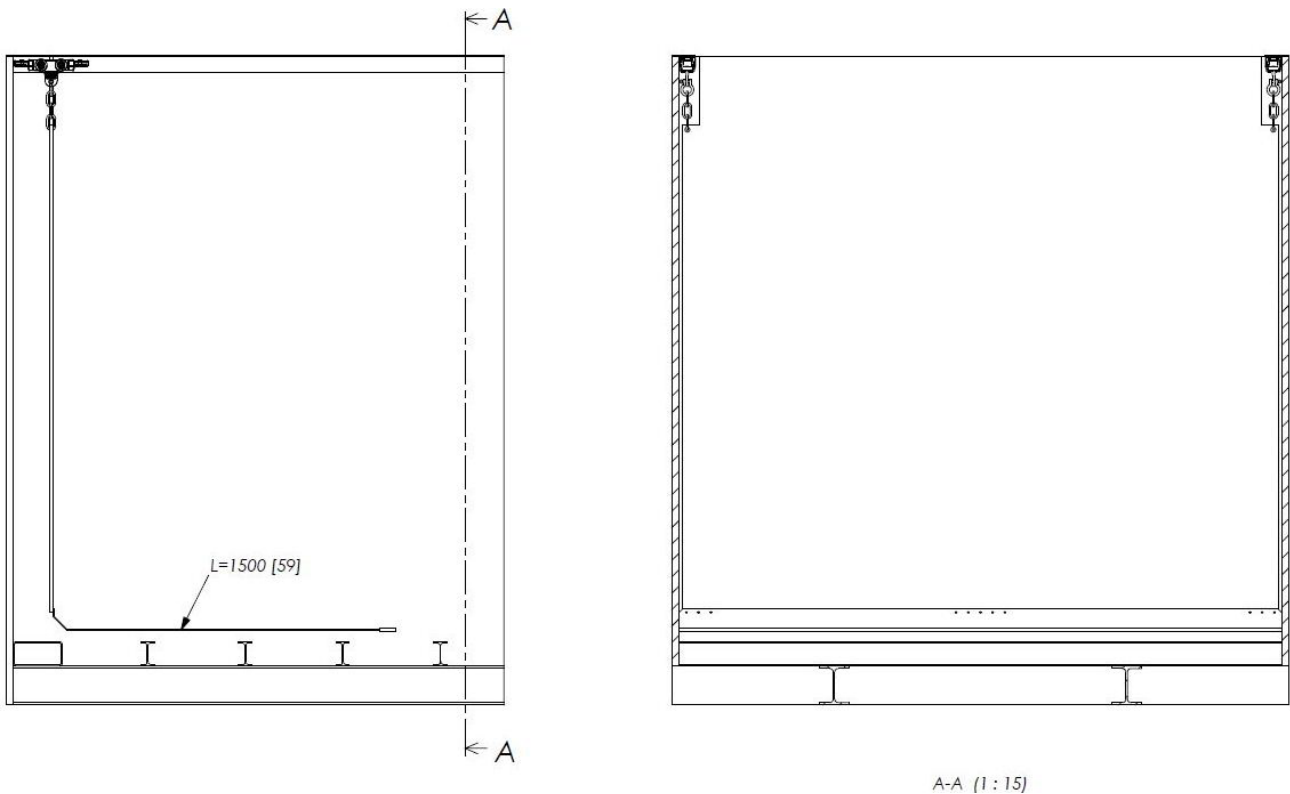

Adjustment of the threaded rod of the control valve

Front side trailer

Rear side trailer

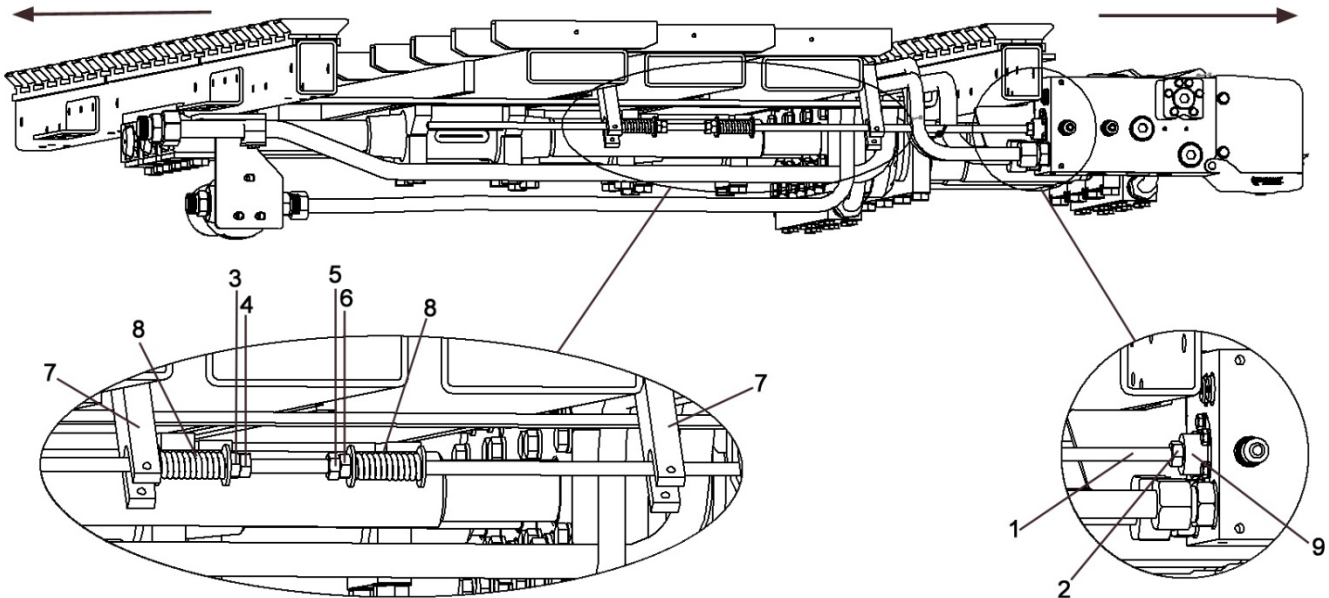

All Hyva Floor systems have the threaded rod set and are fully tested. You therefore do not need to adjust the threaded rod, but in certain circumstances (f.e. certain repairs) it may be necessary to check or adjust the setting of the threaded rod. If switching spontaneously doesn't go normally anymore, then please make a good assessment first why this has happened.

Attention:

The pump and electrical installation must always be switched-off when working on the system; in addition, the hoses and/or pipelines between the pump and the Hyva Floor should also be disconnected.

If not the risk of entrapment arises!!!

Necessary tools:

- 2x spanner 17;
- High viscosity oil;
- Copper grease;
- Steel brush.

Check that the threaded rod (1) is fastened securely to the switching valve, with pressing and pulling the stroke is exactly 12 mm. [0.5"].

If not, then screw the threaded rod (1) as far as possible into the plunger and secure this with the contra nut (2) (spanner size 17). Loosen nuts (3 and 4, spanner size 17) and move these about 3 cm [1.25"] in the direction of the rear of the trailer.

Now switch the pump on while you are at a safe distance. The system will start to move and stops automatically at the point where the command lip (7) no longer operates the switching valve, because the spring (8) is no longer pushed. Switch off the pump immediately.

Now push the threaded rod (1) in the direction of the rear of the trailer until the spacer ring (9) touches the control valve.

Tighten nuts (3 and 4) so far in the direction of the front side of the trailer that the spring is fully pushed in, and secure them by tightening them against one another. Repeat this procedure for the other side (nuts 5 and 6) by doing everything in opposite directions.

N.B. It is worthwhile spreading some copper grease on the threaded rod (1).

40 TON FLOOR LEAK RESISTANCE ASSEMBLY INSTRUCTIONS

Technical specifications

- System operation** : fully hydraulic, with three double-action cylinders
System control : fully hydraulic mechanical
Controls : fully automatic loading – stop – unloading, optional A/B-control

	HF500 SLC	
Bore (mm)	100	[4"]
Piston rod diameter (mm)	45	[1.77"]
Stroke (mm)	200	[8"]
Cylinder volume (litr)	2,82	[0.75 us gal]
Oil volume per cycle (litr)	8,46	[2.25 us gal]
Over pressure valve threshold, max. operational pressure (bar)	225	[3,300 psi]
Strokes per minute with advised pump capacity	13	
Speed (mtr./min.) with advised pump capacity	2,6	[8.5 ft./min]
Advised pump capacity:		
Flow (litr./min.)	110	[29 gpm]
Pressure (bar)	250	[3,625 psi]
Max. pump capacity:		
Flow (litr./min.)	130	[34.5 gpm]
Pressure (bar)	250	[3,625 psi]
Speed at maximum pump capacity (mtr./min.)	3,1	[10 ft./min]

- Control valves** : 24V DC
Throughput variation : completely variable speed by use of oil flow determined by the revs of the motor or by various pumps. Pay attention to the diameter of the choke, see chapter [connecting the hydraulics](#).
Drive : use of the PTO/pump on the truck; an electro-hydraulic aggregate or a hydraulic aggregate with an external combustion engine.
Filter : pressure filter type: high-pressure 10 micron
Pressure piping : Ø 20 x 2 feed through 16 mm
Return piping : Ø 25 x 2,5 feed through 20 mm
Oil ISO VG 32 : Shell Tellus T32 or BP HL2-32 or ESSO Unavis 32 (or equivalent).
 Only use biological oil after agreement by Hyva Floor
Biological oil : a biological oil of the type synthetic ester (HEES) can be used as standard with the HF500 SLC system. We advise you not to use other types of biological oil.
Oil temperature : max. 100 °C [212 °F]
Floor Profiles : aluminium
 Profile length negotiable
Quality : high quality alloy, weldable, very wear-proof and tensile
Bearing : the aluminium floor profiles are supported by wear-resistant plastic bearings
Under floor : length negotiable

40 TON FLOOR LEAK RESISTANCE ASSEMBLY INSTRUCTIONS

Maintenance instructions

When works require turning on the floor you should take care of that the floor can be shut down immediately at any time. Places where clamping/clasping of body parts is possible may not be approached when the system is moving.

For more detailed explanation of the execution of the works we would like to refer you to our website:

www.hyva.com.

Check for the end user / owner after receipt of the new Hyva Floor trailer

Check a couple of days after receipt of the new trailer and / or after 10 loads / unloads and after one month the connection between the aluminium floor profiles and the Hyva Floor system. You do this by placing your finger half on the screw and half on the floor profile when the floor is operating.

Important: if you feel a difference in movement between the screw and the floor profile it means the floor profile is not fastened enough. The screw connection of the whole profile group this concerns needs to be renewed with new screws in accordance to the fastenings guidelines mentioned in the assembly instructions (see www.hyva.com, downloads). Also the countersunk hole needs to be cleaned properly. Do not check the screw connections with the help of an Allen key and do not simply just tighten the screws, the Loctite connection will be broken.

Specifications of the screws: hexagon socket countersunk head screw M12 x 40, article number 502112040.2. The torque is 100 - 140 Nm [72-105 lbf.ft.]

Regular checks and preventive maintenance

To ensure that your Hyva Floor system operates reliably and has a long life, it is important that you regularly perform careful checks on the following aspects:

- Replace the filter element every year, or more often if needed. By removing the filter lid/chamber you can check the filter element,
- Change the oil every 2 years, or more frequently if required;
- The level of oil in the tank. See for oil levels and the oil specifications the technical specifications.
- Floor profiles: are they still fixed, replace screws if necessary!
- Check the guide blocks for the 3 piston rods for wear
- Check the coupling nuts and couplings of all hydraulic components, and adjust if necessary!
- Oil tank: by taking the lid off the tank, you can remove any remains (condensation, dirt etc.) from the bottom.
- Check the seal between the two fixated floor profiles and the moving profiles. If a margin exists in-between, then adjust the fixated floor profiles, in order for the sealing to be optimal and leakage via the side walls is prevented
- Clean the floor.

This is all necessary to avoid internal wear (of the pump/cylinders etc., for example).

New filter parts are available at your system builder. For the right type we refer you to our “exploded views” which you can find on our website: www.hyva.com, downloads.

We want to emphasize that the minimal costs of replacing dirty parts or oil do not match the costs and discomfort that can arise.

Cleaning the floor parts with a steam cleaner is also part of the regular preventative maintenance, especially with the so called SLP profiles this is mandatory to clean the large gully regularly.

40 TON FLOOR LEAK RESISTANCE ASSEMBLY INSTRUCTIONS

Important instructions

- Avoid letting dirt and water get into the hydraulic system when disconnecting the connectors or when topping up/cleaning the oil tank.
- Adjust the work speed when, for example, heavy massive products are being loaded or unloaded with which the system needs the maximum power ([see chapter technical specifications](#)), so as to avoid overloading.
- It is not permitted to exceed the maximum operational pressure ([see chapter technical specifications](#)).
- Avoid loading and unloading sharp objects without a protective roll-up cover mechanism. This causes unnecessary wear of the seal/floor profiles. If you would like to transport such materials safely, we advise you to use a protective roll-up cover mechanism.
- Never exceed the maximum number of strokes per minute when using the full stroke ([see chapter technical specifications](#)). A greater number of strokes causes enormous forces in the system and chassis, and causes a lot of heat to be generated in the hydraulic system.
- When loading and unloading packed goods it is important that a good equal weight distribution is realized on the floor. If this is not the case there is the possibility that the goods will not move. When using pallets, if necessary, place a wooden plank (of about 300x18x2350 mm [12"x 0.75"x92.5"]) multiplex underneath.

40 TON FLOOR LEAK RESISTANCE ASSEMBLY INSTRUCTIONS

Troubleshooting E-control

In the event of the failure of the Hyva Floor system to operate (in the correct manner) when used in accordance with the operating instructions carry out the following checks:

Malfunction system	Concerns part	Cause	Solution
1. Does not operate No oil flow control valve	PTO	Not switched on	Switch on PTO
	Quick coupling	Blockade	Check couplings / mount correctly
2. Does not operate There is oil flow control valve	Switch	Stop operated	De-activate stop
	Solenoid valve GS02 on/off	Interruption wiring Interruption in coil	Activate manual override GS02 temporarily and/or repair power supply
	Pressure control valve	Polluted	Clean / replace pressure control valve, attention: do not open the pressure control valve in parts
	Oil temperature switch	Interruption solenoid due to overheating	Let the oil cool down.
	Operation plunger in the middle position	Flow <60 l/m [16 US gpm] See chapter: choke	Increase pump rpm Install another pump Adjust choke
		Hoses connected reversed	Check filter first, then connect pressure and return correctly.
3. Starts immediately after switching on the PTO	Switch HF7	Switch movement blocked in the on position	Remove blockade
	GS02 on/of	Manual override activated	De-activate manual override, put yellow security clip back in place
	Hoses connected reversed	Pressure and return hoses are swapped	Check filter first, then connect pressure and return correctly.
4. Individual movement is difficult and/or incorrect with a full trailer	Pressure control valve	Tipper valve	Turn tipper valve in correct position
		Pressure control valve pulling vehicle max. pressure to low	Measure max. pressure/ adjust pulling vehicle
		Return oil has restrictions	Measure pressure M2, remove restrictions
	Capacity of the system is insufficient.	Too much load	Unload part of load with crane
		Pollution between the profiles	Clean
		Frost	Thaw
5. Individual movement is incorrect when unloading With a full and empty trailer	Valve in cylinder head 1 or 2	Pollution prevents a good closure	Remove pollution
		Broken valve spring	Replace spring
	Valve seat in cylinder head 1 or 2	Valve seat has loosened	*Replace / fasten valve seat
	Common rail cylinder rod side	Stop in the common rail has loosened	Fasten stop / replace common rail
		Common rail mounted the wrong way around	Mount common rail correctly

40 TON FLOOR LEAK RESISTANCE ASSEMBLY INSTRUCTIONS

Malfunction system	Concerns part	Cause	Solution
6. Switching is difficult or goes not at all. 3 Cylinders are fully retracted or fully out.	a. Threaded rod	Adjustment incorrect	Adjust correctly, attention: determine cause. See: b. and c.
		Switching spring broken	Replace spring, attention: determine cause. See: b. and c..
	b. Switching plunger	Stroke > 12 mm. [0.5 inch] -> threaded rod loose, spacer loose	Screw in Threaded rod / bolt fully.
	c. Moving cross member	Slanting caused by loose profiles	*Replace screws and provide them with a thread locking product and check the rod bearing.
	d. Switching choke	Polluted	* Clean choke
7. Floor unloads when choosing loading and unloading	Solenoid valve G02 loading / unloading	Interruption wiring Interruption in coil	Activate manual override G02 temporarily and/or repair power supply
8. Floor loads when choosing loading and unloading	Solenoid valve G02 loading / unloading	Manual override G02 is activated	De-activate emergency control
9. Other malfunctions	Please contact your trailer builder or Hyva Floor, keep the system number at hand.		

* Contact us for the right repair advice.

40 TON FLOOR LEAK RESISTANCE ASSEMBLY INSTRUCTIONS

Warranty conditions

Warranty shall only be given with the prior consent of Hyva Floor! With warranty requests always fill in and send a warranty request form to Hyva Floor beforehand. You can fill in a request for warranty simply on our website: www.hyva.com.

The warranty conditions, as specified in the most recent “Metaalunie” conditions, filed with the registrar of the District Court of Rotterdam, are applicable in unabbreviated form. On request available.

A short extract of these conditions follows:

A warranty period of 12 months (starting directly after installation) applies for all Hyva Floor system materials supplied by us. In the case of malfunction and/or manufacturing faults we are only responsible for the costless supply of replacement parts, if:

The warranty period is for the first equipment owner only

The Hyva Floor system is installed by your trailer builder according to our installation procedures

Our maintenance and control procedures have been followed

In the case of a malfunction, the system builder, or Hyva Floor have been informed

The following components are not covered by the warranty:

- Malfunction of equipment, or caused by equipment, which was not supplied by Hyva Floor
- Malfunction caused by the use of dirty oil, or oil of the wrong type
- Malfunction caused by overheated oil, T. max. ≤ 100 °C [212 °F]
- Malfunction caused by overloading or injudicious use
- Malfunction caused by improper repair work, or repair work which is carried out by third parties
- Malfunction caused by corrosive materials
- Filter elements and components, which are subject to normal wear-and-tear and are not warranty items
- Defects in electrical components due to incorrect connection and/or incorrect voltage levels
- Consequential damages

The warranty is void if:

- The system is used for purposes, which have not been recommended Hyva Floor
- The wet kit is not as recommend in the Hyva Floor manuals
- The Hyva Floor system is not installed properly
- Load in excess of legal limit are moved as defined in Hyva Floor manuals and operating instructions.
- The Hyva Floor system has not constructed correctly by your trailer builder, insofar as this has a negative influence on the operation of the system.

Hyva Floor hereby warrants, only to the first owner of a new Hyva Floor unloader from the factory or selling distributor, that the Hyva Floor hydraulic parts and hydraulic components shall be warranted as free from defects in material and workmanship for a period of 12 months year to the first registered owner from the date of the sale.

This warranty does not cover normal wear and tear, maintenance, or heat damage. It is not to be construed as a service contract.

Note: Prevention of excessive heat in the hydraulic system is the single most important factor for long system life. Bad pumps, improper wet kits and hydraulic restrictions cause excessive heat and will damage the hydraulic system. Heat damage will void the warranty.

40 TON FLOOR LEAK RESISTANCE ASSEMBLY INSTRUCTIONS

Definition of normal use and service:

Normal use and service means the loading and/or unloading of uniformly distributed, non-corrosive material, properly restrained and secured, on properly maintained public roads, with gross vehicle weights not in excess of factory rated capacity.

Sole and exclusive remedy:

If the product covered hereby fails to conform to the above stated warranty, Hyva Floor sole liability under this warranty and the owner's sole and exclusive remedy is limited to repair or replacement of the defective part(s) at a facility authorized by your dealer or Hyva Floor. This is the owner's sole and exclusive remedy for all contract claims, and all tort claims including those based on the strict liability in tort and negligence. Any defective part(s) must be shipped freight prepaid to your dealer who will contact Hyva Floor.

Except as expressly set forth above, Hyva Floor makes no warranties:

Express, implied or statutory, specifically: No warranties of fitness for a particular purpose or warranties of merchantability are made. Further, Hyva Floor will not be liable for incidental damages or consequential damages such as, but not limited to, loss of use of the product, damage to the product, towing expenses, attorney's fees and the liability you may have in respect to any other reason.

Tort disclaimer:

Hyva Floor shall not have any liability in tort with respect to the products, including any liability based on strict liability in tort and negligence.

If this warranty violates law:

To the extent any provision of this warranty, contravenes the law of any jurisdiction, that provision shall be inapplicable in such jurisdiction and the remainder of the warranty shall not be affected thereby.