

EDGE LINE
RAISE YOUR GAME



ARTICULATED CRANES WITH ULTIMATE PRECISION AND LIFTING CAPACITY

HC 661e 



RAISE YOUR GAME HYVA PERFORMANCE

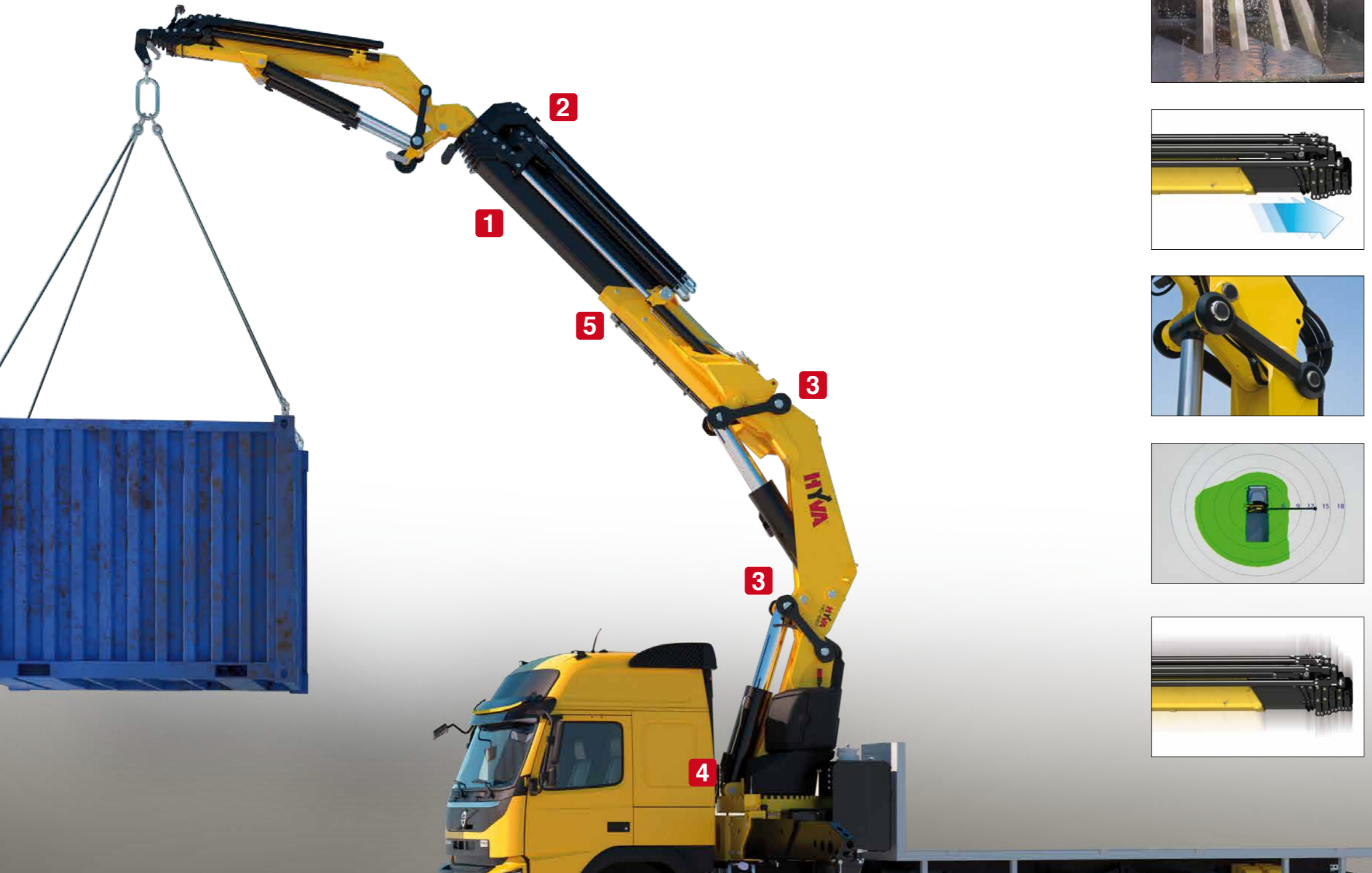

TOP SOLUTIONS

1 TPP



- **Top protection painting** - Top quality cathaphoresis treatment and paint process on all crane components ensures higher value retention and durability.
 - Bolts and nuts protected by Geomet® treatment: 890% more resistance against corrosion.
- Top quality protection for harsh environment**

2 EES

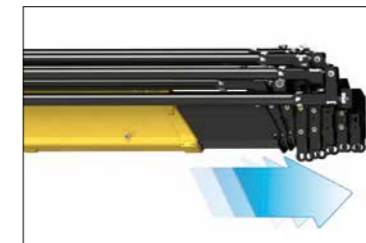

- **Extra Extension Speed** - The market is always demanding more speed along with the highest possible safety. EES is the answer. Through the use of a specially designed counterbalance valve, this system increases the extension speed without affecting the crane's safety.
- Save time, precise work, increase efficiency**

3 LAS



- **Liftrod Articulating System** - Joins forged double linkages on the column and second boom. Its design raises the mechanical advantage of the articulation to provide consistent force through all working angles.
- Precision and versatility for all working positions**

4 DLD

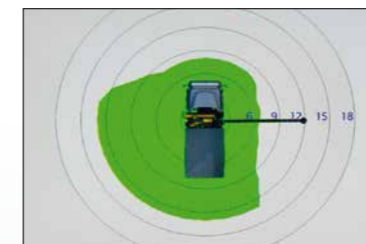

- **Dynamic Load Diagram** - After the stabilization, operator can select the load to be lifted. Display shows the permitted crane outreach based on the stability and the load selected.
- Crane lifting capacity always under control in all stabilizer positions**

5 SDS



- **Smooth Descent System** - Uses a special counterbalance valve to reduce boom oscillation, the result for the user is incredible precision in unloading operations.
- Control and precision of the movement**



CRANE CONTROL SYSTEM



P-CLASS

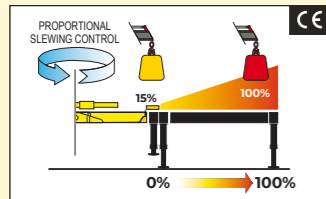

- Proportional stabilizers control
- Proportional slewing control
- Truck side independent

HUMAN MACHINE INTERFACE



SMART TOP MONITOR 7"



Up to 16 languages available into the software. Top choice available for the range. Data statistics and crane management, all included into a 7" TFT monitor giving to the operator a higher level of awareness of the crane.

SMART AND USER-FRIENDLY CONTROLS

Control station distinguished by operator comfort and user-friendly interface derived from dedicated ergonomic and user preference studies



SMART TOP MONITOR 7"
Simple and quick access to all the functions and information

Vertical stabilizers levers
Safe and fast. Excellent supervision of stabilizing operation

CRANE CONTROLS



LCD REMOTE CONTROL



Each transmitter is equipped with 8 ergonomic proportional levers (6 for Scanreco mini) to control up to 8 functions of the crane. Using two hands, the operator can move 2-3-4 functions at once. This ensures more speed in loading or unloading operations with high precision.



GRAPHIC REMOTE CONTROL



Top visualization on 3" graphic display on the remote transmitter. Improved crane data visualization and crane control. Top level class of offer in the range.

TECHNICAL SOLUTIONS TO RAISE RELIABILITY AND SAFETY

New Stability Logic for maximum level of flexibility

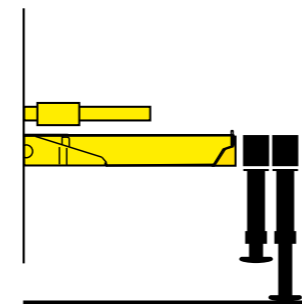

- Be free to maximize the use of your crane for all stabilizers' positions.

Working flexibility: performance in any situation



- Endless slewing allows the crane to be operated without restrictions. The complete access to the working area, eliminates the need to reposition the truck, optimizing precision, productivity and safety.

Electronics mind: guaranteed in all conditions



- All electrical components have IP69K enclosures which offer complete protection against water jet and dust penetration providing higher durability and less down time.

A TEAM OF SKILLED AND CARING SPECIALISTS

Easy installation and smart calibration cranes, combined with a high level of service, make Hyva the best partner for your business - all over the world



Compact, light and strong architecture



- Uniquely designed to reduce the space occupancy behind the cabin made for increasing payload and truck floor area.

MOREOVER HC661e IS THE STRONGEST IN ITS RANGE

OUR INNOVATIONS ARE CHANGING THE GAME

Solutions that are the result of smart engineering

ALS AUTO LEVELLING SYSTEM



Keep truck horizontal for best crane's performance. This system automatically keeps the truck frame in horizontal position, enabling the crane to perform always at its best.



OAD OPERATOR AUTO DETECTION

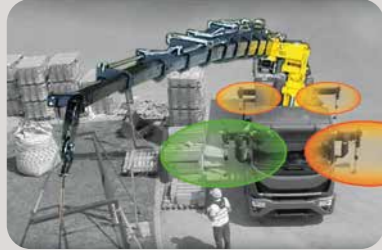

Detection and automatic activation of the operator's closest stabilizer. The Proximity Detection Module installed on each stabilizer allows to automatically activate the operator's closest stabilizer, avoiding potential human error.

DLD DYNAMIC LOAD DIAGRAM



This system, a first on truck-mounted articulated cranes, optimises stabilization, makes crane operation safer and more efficient and allows the driver to verify in advance the crane lifting capacity based on truck stability. A graphic display shows the outreach available for the load selected and the actual boom slewing position.

ONE CRANE, MANY APPLICATIONS

Thanks to the extensive range of accessories and attachments



Building



Construction



Energy



Environment



Gardening



Logistics



Maintenance



Mining



Oil&Gas



Rental

TECHNICAL INFORMATION HC661e X

Dimensions (mm)

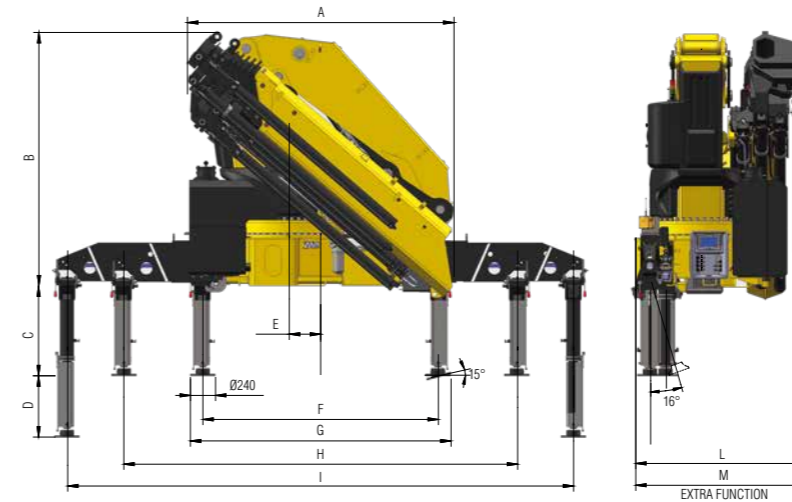

	E2	E4	E6	E8	E6J2002	E6J2004	E6J2006	E6J1206
A	2530	2530	2530	2550	2550	2550	2550	2550
B	2430	2430	2430	2430	2740	2740	2740	2780
C	860	860	860	860	860	860	860	860
D	586	586	586	586	586	586	586	586
E	300	300	300	300	300	300	300	300
F	2255	2255	2255	2255	2255	2255	2255	2255
G	2495	2495	2495	2495	2495	2495	2495	2495
H	6660	6660	6660	6660	6660	6660	6660	6660
I	8670	8670	8670	8670	8670	8670	8670	8670
L	1480	1480	1480	1635	1665	1665	1665	1665
M	1585	1585	1585	1690	-	-	-	-

Load diagrams

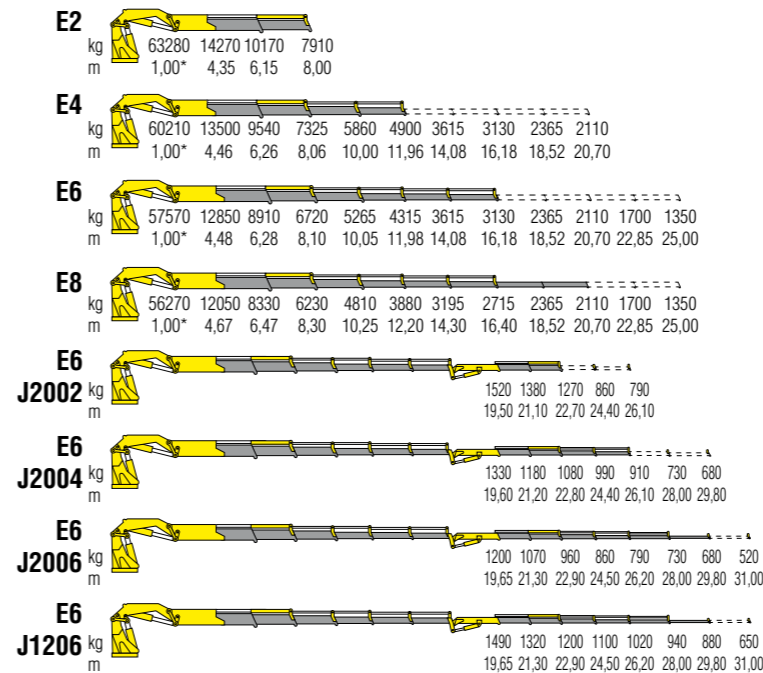

Standard features

- Designed in accordance with:**
EN12999:2020 + EN13849
Design class: HC1-HD5
- Multifunction radio remote control
 - Sauer Danfoss PVG32
 - On site auxiliary manual controls (on column)
 - P-LCS Proportional Lift Control System
 - EES Extra Extension Speed
 - SDS Smooth Descendent System
 - LAS Liftrod Articulating System
 - 7" color display
 - High pressure oil filter
 - Flanged valves
 - Load sensing pump predisposition
 - Stabilizers control valve
 - Hydraulically extendable stabilizers
 - Fixed stabilizer cylinders
 - Swivel stabilizer foot
 - Stability Control System (CE)
 - Visual warning device for closed stabilizers (CE)
 - P Class - Crane Control System (CE)
 - Smart Top Monitor 7" - Human Machine Interface

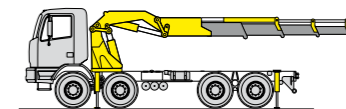

Recommended truck
 M.T.T. ton 42 - G.V.W. ton 42

Technical specifications

		E2	E4	E6	E8	E6J2002	E6J2004	E6J2006	E6J1206
Lifting Moment	tm	63,2	60,2	57,5	56,2	29,6	26,0	23,5	29,2
Slewing Angle	°	endless	endless	endless	endless	endless	endless	endless	endless
Working pressure	bar	365	365	365	365	-	-	-	-
Oil tank capacity	l	250	250	250	300	250/300	250/300	250/300	250/300
Max Oil flow	l/min	100	100	100	100	100	100	100	100
Max lifting height	m	11,9	15,9	20,3	24,7	26,6	30,1	33,8	33,8
Standard crane weight	kg	5375	5940	6465	6875	7570	7785	7955	7655

110 countries
+3,500 employees
20,000 customers
+30 subsidiaries
14 production facilities



Hyva is a leading provider of innovative and highly efficient transport solutions for commercial vehicles used in transport, construction, mining, materials handling and environmental service industries.

Founded in 1979 in the Netherlands, the company has a global presence with more than 30 wholly owned subsidiaries, extraordinary service coverage and 14 manufacturing facilities in Brazil, China, Europe and India.

For more information on Hyva, please visit www.hyva.com

or follow us on:



Hyva Holding B.V.
Antonie van Leeuwenhoekweg 37
2408 AK Alphen aan den Rijn
The Netherlands
Telephone: +31 (0)172 - 42 35 55
Telefax: +31 (0)172 - 42 08 80
info@hyva.com
www.hyva.com



**Quality and
environmental certified**

DEALER STAMP