

EDGE LINE
RAISE YOUR GAME



ARTICULATED CRANES WITH ULTIMATE PRECISION AND LIFTING CAPACITY

HC 445e 



RAISE YOUR GAME HYVA PERFORMANCE



TOP SOLUTIONS

1 TPP

- **Top protection painting** - Top quality cataphoresis treatment and paint process on all crane components ensures higher value retention and durability.
 - Bolts and nuts protected by Geomet® treatment: 890% more resistance against corrosion.
- Top quality protection for harsh environment**

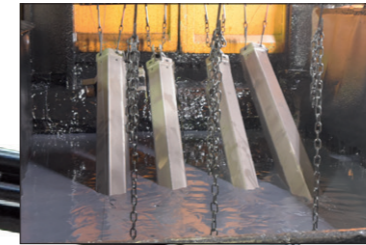

2 EES

- **Extra Extension Speed** - The market is always demanding more speed along with the highest possible safety. EES is the answer. Through the use of a specially designed counterbalance valve, this system increases the extension speed without affecting the crane's safety.
- Save time, precise work, increase efficiency**

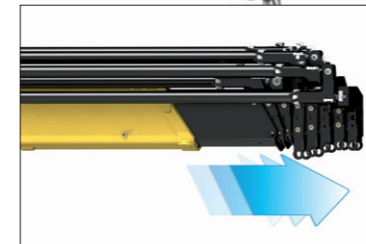

3 LAS

- **Liftrod Articulating System** - Joins forged double linkages on the column and second boom. Its design raises the mechanical advantage of the articulation to provide consistent force through all working angles.
- Precision and versatility for all working positions**



4 DLD

- **Dynamic Load Diagram** - After the stabilization, operator can select the load to be lifted. Display shows the permitted crane outreach based on the stability and the load selected.
- Crane lifting capacity always under control in all stabilizer positions**

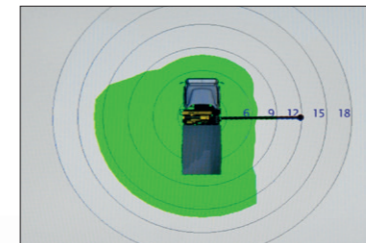

5 SDS

- **Smooth Descent System** - Uses a special counterbalance valve to reduce boom oscillation, the result for the user is incredible precision in unloading operations.
- Control and precision of the movement**

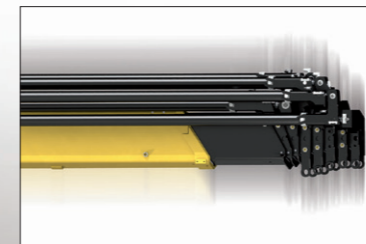



CRANE CONTROL SYSTEM



P-CLASS

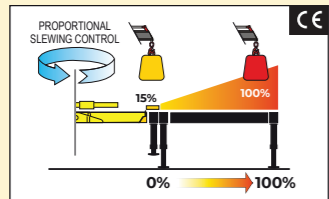

- Proportional stabilizers control
- Proportional slewing control
- Truck side independent

HUMAN MACHINE INTERFACE



SMART TOP MONITOR 7"



Up to 16 languages available into the software. Top choice available for the range. Data statistics and crane management, all included into a 7" TFT monitor giving to the operator a higher level of awareness of the crane.

CRANE CONTROLS



LCD REMOTE CONTROL



Each transmitter is equipped with 8 ergonomic proportional levers (6 for Scanreco mini) to control up to 8 functions of the crane. Using two hands, the operator can move 2-3-4 functions at once. This ensures more speed in loading or unloading operations with high precision.



GRAPHIC REMOTE CONTROL



Top visualization on 3" graphic display on the remote transmitter. Improved crane data visualization and crane control. Top level class of offer in the range.

P-LCS - Proportional Lift Control System

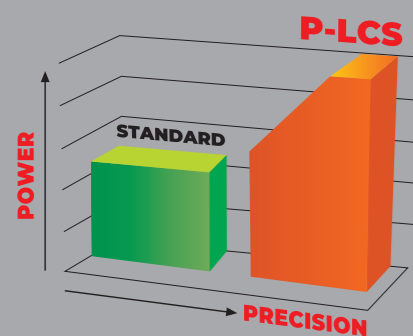

P-LCS system can reach longer outreach with very heavy load, with the highest precision.

- Hyva Power Boost enables the crane to reach further and lift more. This is accomplished by reducing the oil flow through a flow divider and increasing the maximum available pressure. In high load conditions, this gives the operator more control and lift capacity. P-LCS engages and disengages automatically, so there is no reduction in speed during light/medium crane loading.

SMART AND USER-FRIENDLY CONTROLS

Control station distinguished by operator comfort and user-friendly interface derived from dedicated ergonomic and user preference studies



SMART TOP MONITOR 7"
Simple and quick access to all the functions and information

Vertical stabilizers levers
Safe and fast. Excellent supervision of stabilizing operation

TECHNICAL SOLUTIONS TO RAISE RELIABILITY AND SAFETY

New Stability Logic for maximum level of flexibility

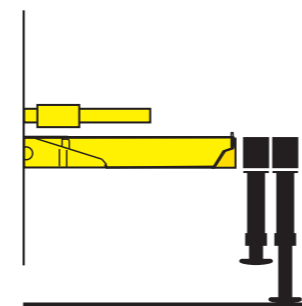

- Be free to maximize the use of your crane for all stabilizers' positions.

Working flexibility: performance in any situation



- Endless slewing allows the crane to be operated without restrictions. The complete access to the working area, eliminates the need to reposition the truck, optimizing precision, productivity and safety.

Electronics mind: guaranteed in all conditions



- All electrical components have IP69K enclosures which offer complete protection against water jet and dust penetration providing higher durability and less down time.

OUR INNOVATIONS ARE CHANGING THE GAME

Solutions that are the result of smart engineering



DLD DYNAMIC LOAD DIAGRAM

This system, a first on truck-mounted articulated cranes, optimises stabilisation and makes crane operation safer and more efficient, allows the driver to verify in advance the crane lifting capacity based on the truck stability. A display shows the outreach available for the load selected and the actual boom slewing position.

A TEAM OF SKILLED AND CARING SPECIALISTS

Easy installation and smart calibration cranes, combined with a high level of service, make Hyva the best partner for your business - all over the world



ONE CRANE, MANY APPLICATIONS

Thanks to the extensive range of accessories and attachments



Building



Construction



Energy



Environment



Gardening



Logistics



Maintenance



Mining



Oil&Gas



Rental

TECHNICAL INFORMATION HC445e X

Dimensions (mm)

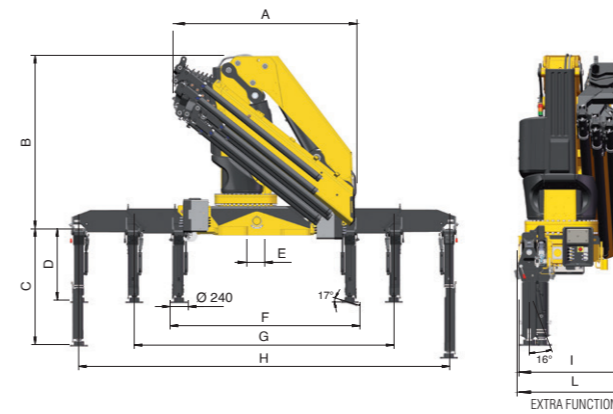

	E2	E3	E4	E5	E6	E7	E8
A	2160	2275	2375	2470	2510	2510	2510
B	2465	2465	2465	2465	2465	2465	2465
C	1481	1481	1481	1481	1481	1481	1481
D	895	895	895	895	895	895	895
E	249	249	249	249	249	249	249
F	2500	2500	2500	2500	2500	2500	2500
G	6000	6000	6000	6000	6000	6000	6000
H	7800	7800	7800	7800	7800	7800	7800
I	1210	1240	1240	1240	1240	1345	1345
L	-	-	-	-	-	1390	1390

	E4J1003	E4J1004	E5J1003	E5J1004	E6J1003	E6J1004	E6J1005
A	2500	2500	2500	2500	2510	2510	2510
B	2760	2760	2760	2760	2760	2760	2760
C	1481	1481	1481	1481	1481	1481	1481
D	895	895	895	895	895	895	895
E	249	249	249	249	100	100	100
F	2500	2500	2500	2500	2500	2500	2500
G	6000	6000	6000	6000	6000	6000	6000
H	7800	7800	7800	7800	7800	7800	7800
I	-	-	-	-	-	-	-
L	1330	1330	1330	1330	1330	1330	1330

Load diagrams

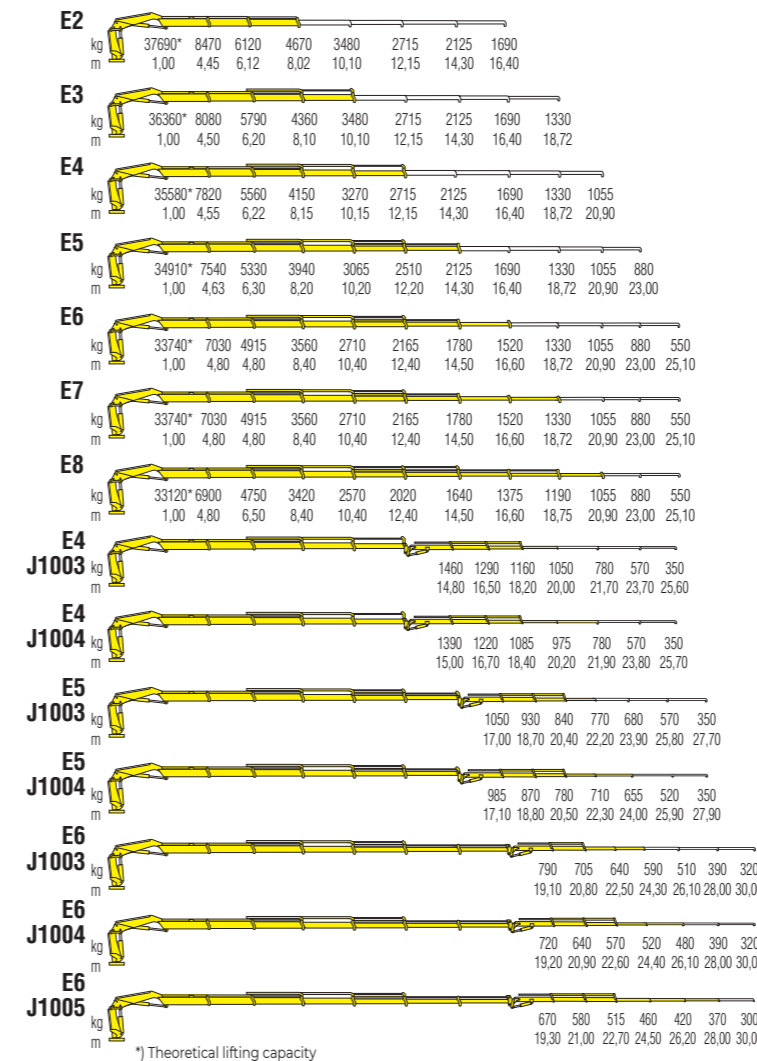

Standard features

Designed in accordance with:
EN12999:2020 + EN13849
Design class: HC1-HD5

- Multifunction radio remote control HETRONIC
- Sauer Danfoss PVG32 (CE)
- Flanged valves
- Hydraulically extendable stabilizers
- Swivel stabilizer foot
- Stabilizers control valve
- Internal stabilizers pipes
- Centralized greasing system
- EES Extra Extension Speed
- SDS Smooth Descent System
- LAS Liftrod Articulating System
- P-LCS Proportional Lift Control System
- P Class - Crane Control System (CE)

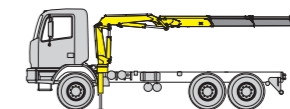

Recommended truck
M.T.T. ton 26

Technical specifications

	E2	E3	E4	E5	E6	E7	E8	E4J1003	E4J1004	E5J1003	E5J1004	E6J1003	E6J1004	E6J1005	
Lifting Moment	tm	37,7	36,4	35,6	34,9	34,2	33,7	33,1	21,6	20,9	17,9	16,8	15,1	13,8	12,9
Slewing Angle	°	Endless	Endless	Endless	Endless	Endless	Endless	Endless	Endless	Endless	Endless	Endless	Endless	Endless	Endless
Working pressure	bar	325	325	325	325	325	325	325	325	325	325	325	325	325	325
Oil tank capacity	l	230	230	230	230	230	230	230	2320	230	230	230	230	230	
Max Oil flow	l/min	100	100	100	100	100	100	100	100	100	100	100	100	100	
Max lifting height	m	12,0	14,0	16,0	18,0	20,0	22,6	24,8	24,3	26,1	26,4	28,2	28,5	30,4	32,3
Standard crane weight	kg	4100	4330	4550	4760	4950	5130	5300	5220	5290	5430	5500	5620	5690	5750

110 countries
+3,500 employees
20,000 customers
+30 subsidiaries
14 production facilities



Hyva is a leading provider of innovative and highly efficient transport solutions for commercial vehicles used in transport, construction, mining, materials handling and environmental service industries.

Founded in 1979 in the Netherlands, the company has a global presence with more than 30 wholly owned subsidiaries, extraordinary service coverage and 14 manufacturing facilities in Brazil, China, Europe and India.

For more information on Hyva, please visit www.hyva.com

or follow us on:



Hyva Holding B.V.
Antonie van Leeuwenhoekweg 37
2408 AK Alphen aan den Rijn
The Netherlands
Telephone: +31 (0)172 - 42 35 55
info@hyva.com
www.hyva.com



Quality and
environmental certified

DEALER STAMP