

**EDGE** LINE  
RAISE YOUR GAME



**ARTICULATED CRANES WITH ULTIMATE PRECISION AND LIFTING CAPACITY**

**HC 173**



# RAISE YOUR GAME HYVA PERFORMANCE

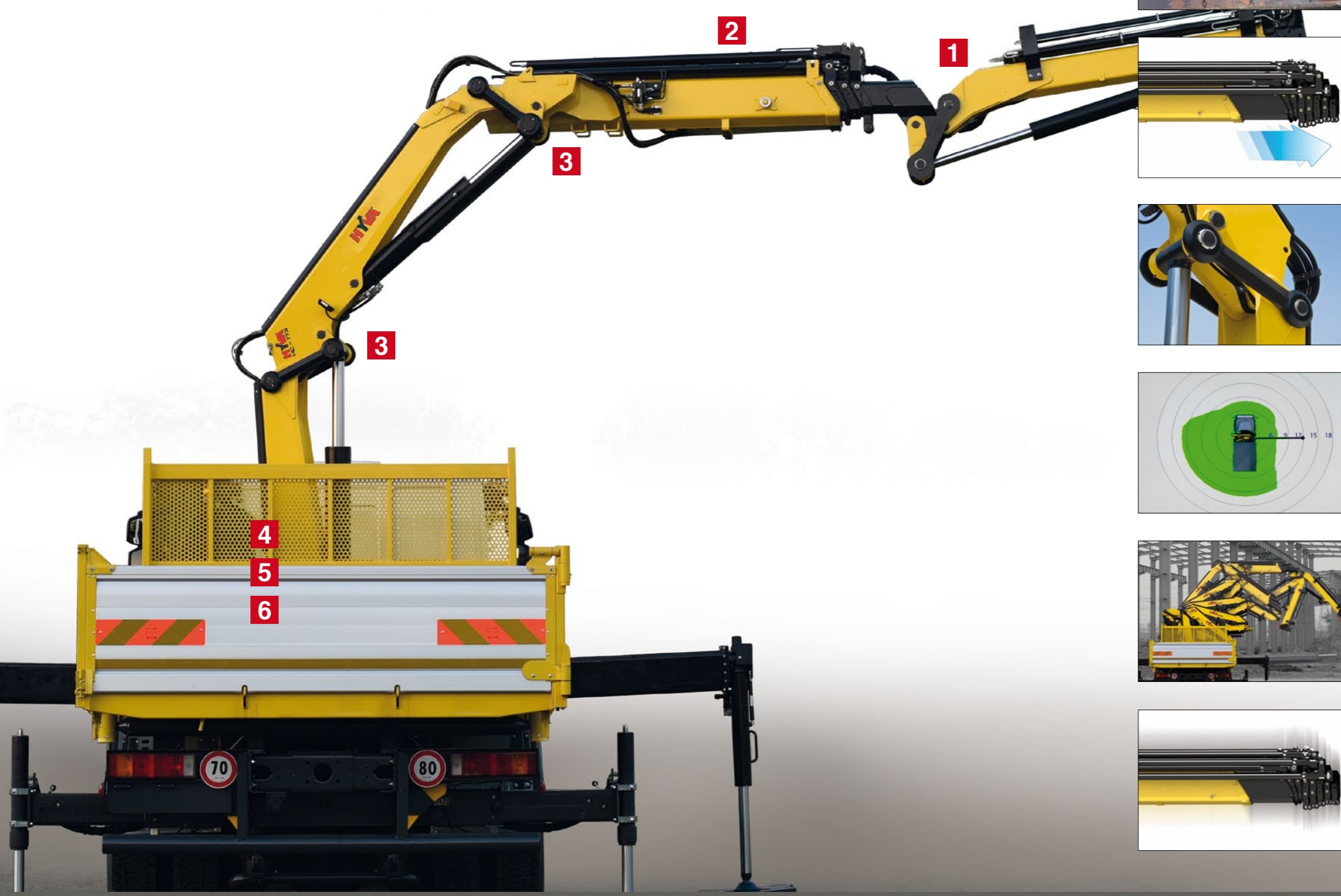

## TOP SOLUTIONS

### 1 TPP

- **Top protection painting** - Top quality cathaphoresis treatment and paint process on all crane components ensures higher value retention and durability.
- Bolts and nuts protected by Geomet® treatment: 890% more resistance against corrosion.

**Top quality protection for harsh environment**



### 2 EES

- **Extra Extension Speed** - The market is always demanding more speed along with the highest possible safety. EES is the answer. Through the use of a specially designed counterbalance valve, this system increases the extension speed without affecting the crane's safety.

**Save time, precise work, increase efficiency**

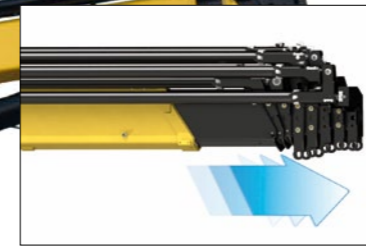

### 3 LAS

- **Liftrod Articulating System** - Joins forged double linkages on the column and second boom. Its design raises the mechanical advantage of the articulation to provide consistent force through all working angles.

**Precision and versatility for all working positions**



### 4 DLD

- **Dynamic Load Diagram** - After the stabilization, operator can select the load to be lifted. Display shows the permitted crane outreach based on the stability and the load selected.

**Crane lifting capacity always under control in all stabilizer positions**

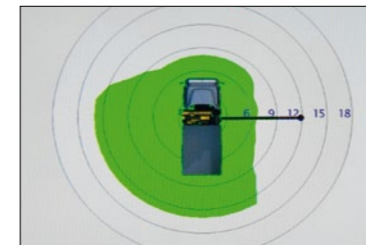

### 5 MT

- **Magic Touch System** - Allows the driver to open the crane from transport position to working position and back by pushing a single lever on the radio transmitter (or a button on the display).

**Crane Automatic folding/unfolding**



### 6 SDS

- **Smooth Descent System** - Uses a special counterbalance valve to reduce boom oscillation, the result for the user is incredible precision in unloading operations.

**Control and precision of the movement**

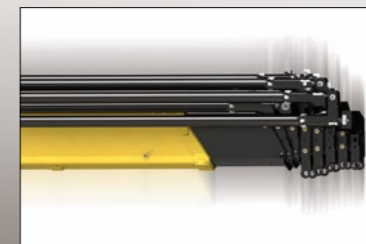

## TECHNICAL SOLUTIONS TO RAISE RELIABILITY AND SAFETY

### Safety first: always stable



- More than 40 stabilizer configurations to ensure safe positioning of the truck in all ground conditions.
- Assisted tiltable stabilizers are the smart solution. Equipped with a gas spring, they provide effortless movement.

### 425° Slewing Angle

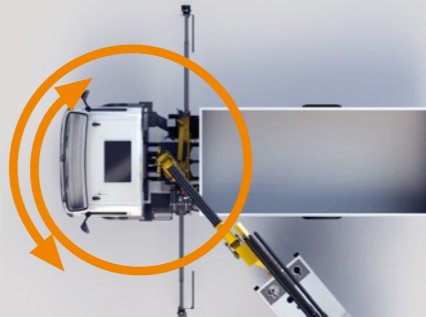

- The widest slewing angle for medium sized cranes.
- Top efficiency and easy to use.

### Electronics in mind: guaranteed in all conditions



- All electrical components have IP69K enclosures which offer complete protection against water jet and dust penetration providing higher durability and less down time.

### Safety Performance Efficiency



#### H3XL

With a 3" TFT display and ergonomic keyboard, the crane operator can select optimum functional parameters. The system controls the stability with 3-steps beam outreach monitoring (cranes with hydraulically controlled stabilizers) or with 2-steps beam outreach monitoring (cranes with manually controlled stabilizers) and continuous slewing control.



#### H4XL

A 7" colour display with integrated keyboard gives the operator a higher level of awareness of the crane operation and allows selection of the best parameters for effective use. The system detects the exact position of the beams and proportionally calculates the stability.

## SMART AND USER-FRIENDLY CONTROLS

Control station distinguished by operator comfort and user-friendly interface derived from dedicated ergonomic and user preference studies

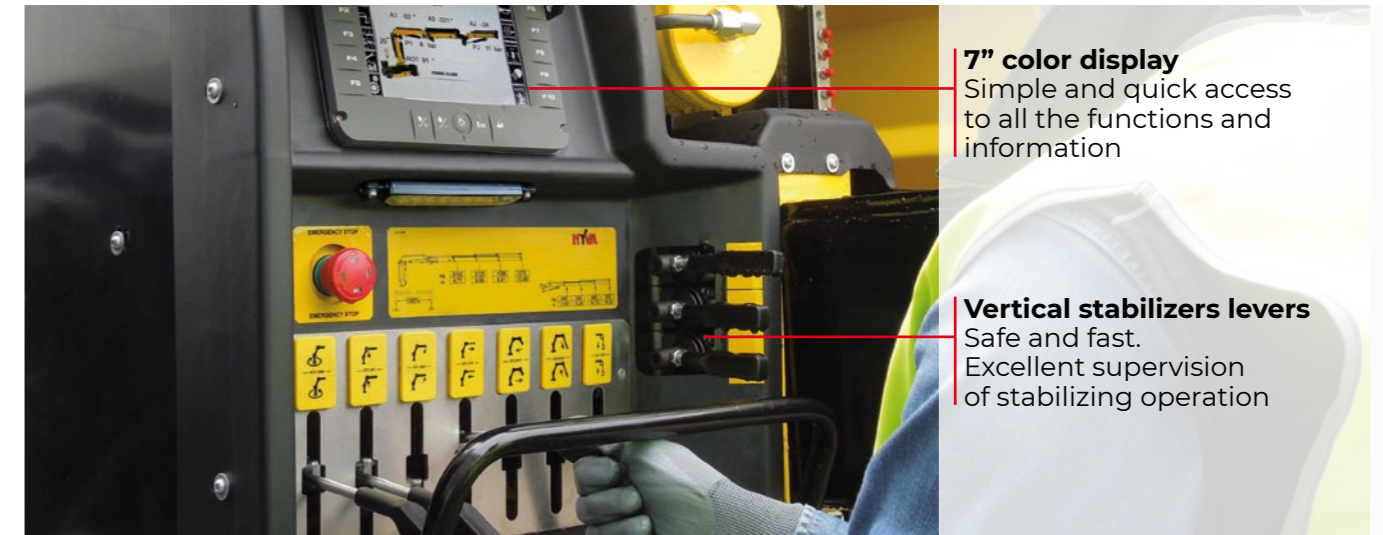

**7" color display**  
Simple and quick access to all the functions and information

**Vertical stabilizers levers**  
Safe and fast. Excellent supervision of stabilizing operation

## OUR INNOVATIONS ARE CHANGING THE GAME

Solutions that are the result of smart engineering

### DLD DYNAMIC LOAD DIAGRAM



This system, a first on truck-mounted articulated cranes, optimises stabilization, makes crane operation safer and more efficient and allows the driver to verify in advance the crane lifting capacity based on truck stability. A graphic display shows the outreach available for the load selected and the actual boom slewing position.

### MT MAGIC TOUCH



This easy-to-use function improves driver attention, promotes safety, saves time and increases productivity. Once the truck is stabilized, a graphic display allows the driver to automatically unfold the crane to a working position and fold the crane from any position to transport position.

### Wide range Radio selection



Hetronic NOT CE



Hetronic CE Basic



Scanreco



Hetronic CE Graphic



distributor  
*Danfoss*

## A TEAM OF SKILLED AND CARING SPECIALISTS

Easy installation and smart calibration cranes, combined with a high level of service, make Hyva the best partner for your business - all over the world



### ONE CRANE, MANY APPLICATIONS

Thanks to the extensive range of accessories and attachments



Building



Construction



Energy



Environment



Gardening



Logistics



Maintenance



Mining



Oil&Gas



Rental

## TECHNICAL INFORMATION HC173

### Dimensions (mm)

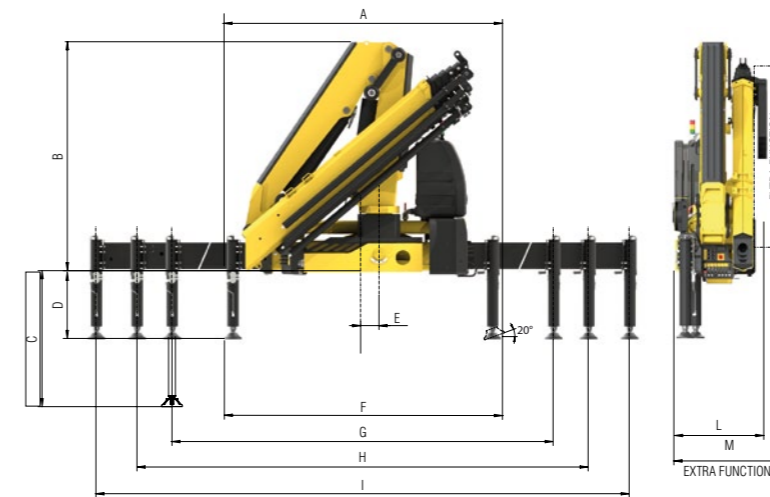

	E2	E3	E4	E5	E6	E3J3
A	2475	2475	2475	2475	2475	2475
B	2330	2330	2330	2330	2330	2615
C	1362	1362	1362	1362	1362	1362
D	670	670	670	670	670	670
E	160	160	160	160	160	160
F	2445	2445	2445	2445	2445	2445
G	4200	4200	4200	4200	4200	4200
H	5400	5400	5400	5400	5400	5400
I	6600	6600	6600	6600	6600	6600
L	825	825	825	905	905	957
M	960	960	960	1020	1020	-

### Load diagrams

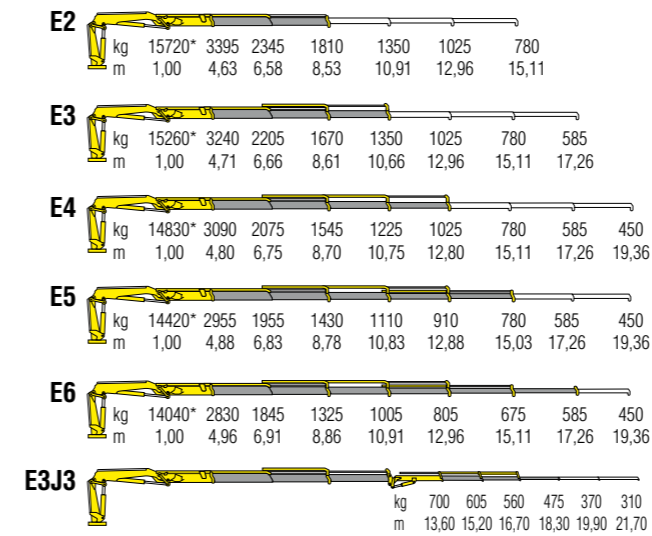

### Standard features

Designed in accordance with EN12999

Design class: HC1-HD4

- Cross controls
- Load limit device
- LCS Lift Control System
- Flanged valves
- Oil tank
- Manually extendable stabilizers
- Internal stabilizer pipes
- Fixed stabilizer cylinders
- Swivel stabilizer foot
- Centralized greasing system
- EES Extra Extension Speed
- SDS Smooth Descent System
- LAS Liftrod Articulating System
- H3XL Crane control system (CE)

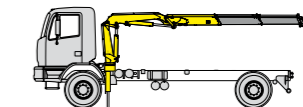

Recommended truck  
M.T.T. ton 15 - G.V.W. ton 15

### Technical specifications - EN12999 - HC1-HD4

		E2	E3	E4	E5	E6	E3J3
Lifting Moment	<b>tm</b>	15,7	15,3	14,8	14,4	14,4	-
Slewing Angle	<b>°</b>	425	425	425	425	425	425
Working pressure	<b>bar</b>	310	310	310	310	310	330
Oil tank capacity	<b>l</b>	130	130	130	130	130	130
Max Oil flow	<b>l/min</b>	40	40	40	40	40	40
Max lifting height	<b>m</b>	12,2	14,4	16,5	18,8	21,0	21,9
Standard crane weight	<b>kg</b>	1995	2125	2245	2355	2450	2615

**110 countries**  
**+3,500 employees**  
**20,000 customers**  
**+30 subsidiaries**  
**12 production facilities**



**Hyva is a leading provider of innovative and highly efficient transport solutions for commercial vehicles used in transport, construction, mining, materials handling and environmental service industries.**

**Founded in 1979 in the Netherlands, the company has a global presence with more than 30 wholly owned subsidiaries, extraordinary service coverage and 12 manufacturing facilities in Brazil, China, Europe and India.**

For more information on Hyva, please visit [www.hyva.com](http://www.hyva.com)

or follow us on:



**Hyva Holding B.V.**  
Antonie van Leeuwenhoekweg 37  
2408 AK Alphen aan den Rijn  
The Netherlands  
Telephone: +31 (0)172 - 42 35 55  
Telefax: +31 (0)172 - 42 08 80  
[info@hyva.com](mailto:info@hyva.com)  
[www.hyva.com](http://www.hyva.com)



Quality and  
environmental certified

DEALER STAMP