

**HB SERIES,
ARTICULATED CRANES BUILT FOR LONG LIFE SERVICE AND
SUITABLE FOR A WIDE RANGE OF TASKS**

**THE MOST VERSATILE AND USER-FRIENDLY CRANE,
SIMPLE, EFFICIENT AND ROBUST**

HB 80



TECHNICAL INFORMATION HB 80



ACCESSORIES

- Supplementary elements activations
- Winch
- Manual extensions
- Manually pivoting stabilizer legs
- Manually extra extensible stabilizers
- Hydraulic extra extensible stabilizers
- Mechanical rotation limitation (No CE)
- Oil cooler
- Top seat
- Operator Full Protection
- Extra cross beams
- "Green" Oil*

CRANE CONTROL SYSTEM

A-CLASS

- N. 2 step stabilizer beams
- N. 1 sector on slewing
- Mono-area pressure limit

E-CLASS

- N. 2 step stabilizer beams
- Proportional slewing control
- Truck side independent

HB 80 X



- Compact dimensions and reduced weight
- Proportional speed control of any single movement
- Stabilizer control by radio

HUMAN MACHINE INTERFACE

BRIGHT LED PANEL

Available for the entire range till **28 tm**. Highly user-friendly design, with buttons and LED lights. Dedicated led lights to identify the position of each stabilizer. New 3-digits display has been added to inform the operator about alarms and errors.

INTELLIGENT DISPLAY 4.3"

Up to **6 languages** available. Full color new display. Offers more information and data compared to the LED Panel. The graphic design and intuitive menu guide the operator and service technician to all the functionality information, statistics and performances.

DIMENSIONS (MM)

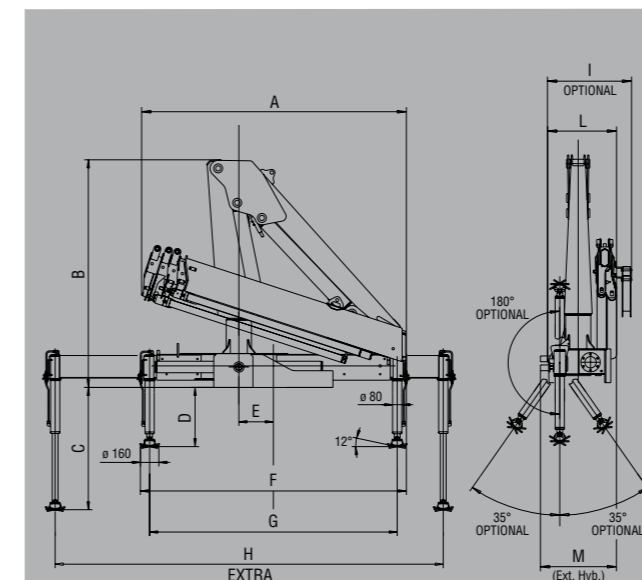

	E1	E2	E3	E4
A	2310	2310	2310	2310
B	1980	1980	1980	1980
C	1060	1060	1060	1060
D	510	150	150	150
E	300	300	300	300
F	2310	2310	2310	2310
G	2150	2150	2150	2150
H	3370	3370	3370	3370
H EXTRA	4600	4600	4600	4600
I	730	730	730	730
L	600	600	600	600
M	660	660	660	660

LOAD DIAGRAMS

HB80 E1

kg	7890*	3220**	2050	1445	1050	790
m	1,00	2,45	3,85	5,40	7,05	8,66

HB80 E2

kg	7690*	3140**	1965	1370	1050	790	600
m	1,00	2,45	3,90	5,46	7,05	8,66	10,35

HB80 E3

kg	7420*	3030**	1865	1290	975	790	600	470
m	1,00	2,45	3,98	5,55	7,10	8,66	10,35	11,95

HB80 E4

kg	7190*	2935**	1760	1200	900	715	600	470
m	1,00	2,45	4,08	5,65	7,20	8,76	10,35	11,95

*) Theoretical lifting capacity
**) Fixed hook capacity

STANDARD FEATURES

- Designed in accordance with: EN12999:2020 + EN13849**
Designed class: HC1 - HD4
- Load limiting device (CE)
 - Hexagonal section extensions
 - Independent extension cylinders
 - Flanged valves
 - Assembly kit
 - Oil tank
 - Fixed stabilizer cylinders
 - Dual controls (No with radio remote control)
 - Light indicator for correct stabilizer stowing (CE)
 - Mechanical rotation limitation (CE)
 - A Class - Crane Control System (CE)
 - LED panel - Human Machine Interface (CE)

TECHNICAL SPECIFICATIONS

		HB 80 E1	HB 80 E2	HB 80 E3	HB 80 E4
Lifting moment	tm	7,89	7,69	7,42	7,19
Max. vertical reach	m	8,50	10,20	11,70	13,30
Slewing angle	°	387	387	387	387
Slewing time	s/180°	15	15	15	15
Max. working heel	°	4	4	4	4
Working pressure	bar	285	285	285	285
Oil tank capacity	l	35	35	35	35
Max. oil flow	l/m	20	20	20	20
Standard crane weight (without stabilizers)	kg	850	930	990	1050

110 countries
+3,500 employees
20,000 customers
+30 subsidiaries
14 production facilities



Hyva is a leading provider of innovative and highly efficient transport solutions for commercial vehicles used in transport, construction, mining, materials handling and environmental service industries.

Founded in 1979 in the Netherlands, the company has a global presence with more than 30 wholly owned subsidiaries, extraordinary service coverage and 14 manufacturing facilities in Brazil, China, Europe and India.

For more information on Hyva, please visit www.hyva.com

or follow us on:



Hyva Holding B.V.
Antonie van Leeuwenhoekweg 37
2408 AK Alphen aan den Rijn
The Netherlands
Telephone: +31 (0)172 - 42 35 55
Telefax: +31 (0)172 - 42 08 80
info@hyva.com
www.hyva.com



**Quality and
environmental certified**

DEALER STAMP