

**HB-R SERIES, THE PERFECT SOLUTION
FOR APPLICATIONS WITH LARGE VEHICLES**

**LARGE, USER-FRIENDLY ARTICULATED CRANES WITH
ULTIMATE PRECISION AND LIFTING CAPACITY**

HB600R



ACCESSORIES

- Assembly kit
- Radio remote control **X**
- Manual extensions
- Supplementary elements activation
- Oil cooler
- Winch
- Hydraulic extra extensible stabilizers
- Automatic and turning stabilizers
- Extra cross-beams

X GENERATION Radio Remote Control

Multifunction radio control



Available
for all models



Pressure compensated
control valve:
SAUER DANFOSS PVG32

LCS LAS

Lift Control System

Lift Control System increases the capacity of the crane up to 10% by reducing the speed when the crane is near its maximum lifting capacity.

Liftrod Articulating System

Thanks to the connecting rods the lifting capacity of the crane is constant in all boom positions.

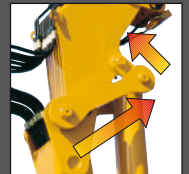

TECHNICAL INFORMATION **HB600R**

LOAD DIAGRAMS

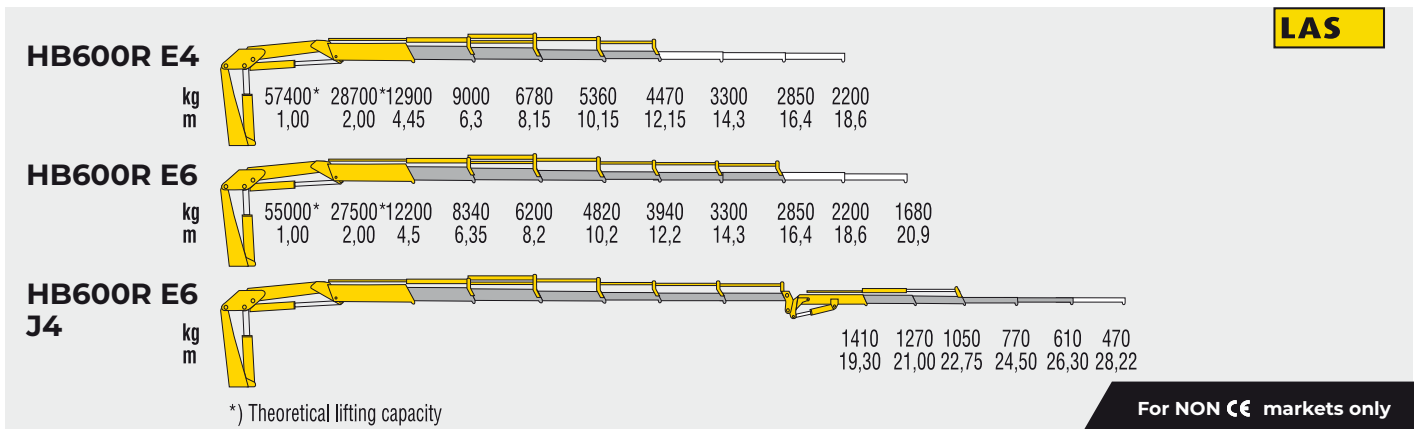

DIMENSIONS (MM)

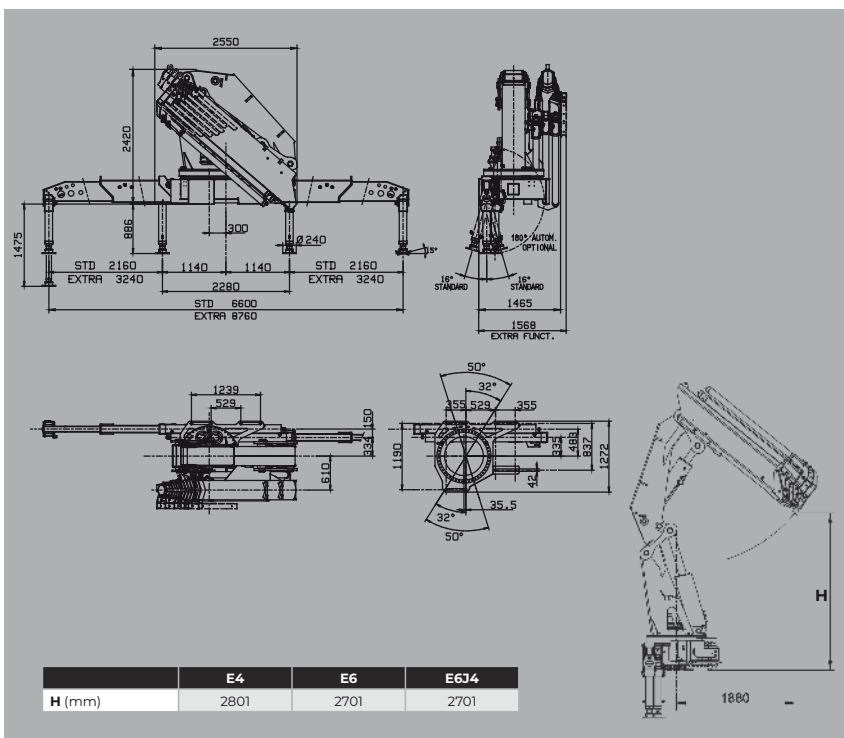

STANDARD FEATURES

- Load limiting device
- Dual controls (NO X)
- Extensions with hexagonal section
- Independent extension cylinders
- Sliding pads on telescopic extensions
- Self-lubricating bushings
- Hydraulically extensible stabilizers
- Flanged valves
- Oil tank
- Swivel stabilizer foot
- Fittings SAE-JIC
- Designed in accordance EN12999-EN13001
- Fatigue test classification: S2
- LAS system

TECHNICAL SPECIFICATIONS

		HB600R E4	HB600R E6	HB600R E6J4
Lifting moment	tm	57,5	-	-
Max. vertical reach	m (hyd. - man.)	16,3 - 22,8	20,5 - 25,0	20,6 - 31,7
Slewing angle	°	428	428	428
Slewing time	s/180°	18	18	18
Max. working heel	°	4	4	4
Working pressure	bar	290	290	285
Oil tank capacity	l	250	250	250
Max. oil flow	l/min.	70	70	70
Standard crane weight (without stabilizers)	kg	5100	5600	6470
weight stabilizers	kg	900	900	900
PBT minimum	t	25	25	25

E = Number of hydraulic extensions - E4 = three extensions

110 countries
+3,500 employees
20,000 customers
+30 subsidiaries
12 production facilities



Hyva is a leading provider of innovative and highly efficient transport solutions for commercial vehicles used in transport, construction, mining, materials handling and environmental service industries.

Founded in 1979 in the Netherlands, the company has a global presence with more than 30 wholly owned subsidiaries, extraordinary service coverage and 12 manufacturing facilities in Brazil, China, Europe and India.

For more information on Hyva, please visit www.hyva.com

or follow us on:



Hyva Holding B.V.
Antonie van Leeuwenhoekweg 37
2408 AK Alphen aan den Rijn
The Netherlands
Telephone: +31 (0)172 - 42 35 55
Telefax: +31 (0)172 - 42 08 80
info@hyva.com
www.hyva.com



DEALER STAMP