

OT30126/7/8/9: VERTICAL STABILIZER

The primary function of the vertical stabilizer is to enhance the stability of the vehicle, especially when it is engaged in loading and unloading operations. When a heavy container or load is being picked up or set down, there can be a significant shift in the center of gravity, which may destabilize the vehicle. The vertical stabilizer provides additional support and counteracts this imbalance.

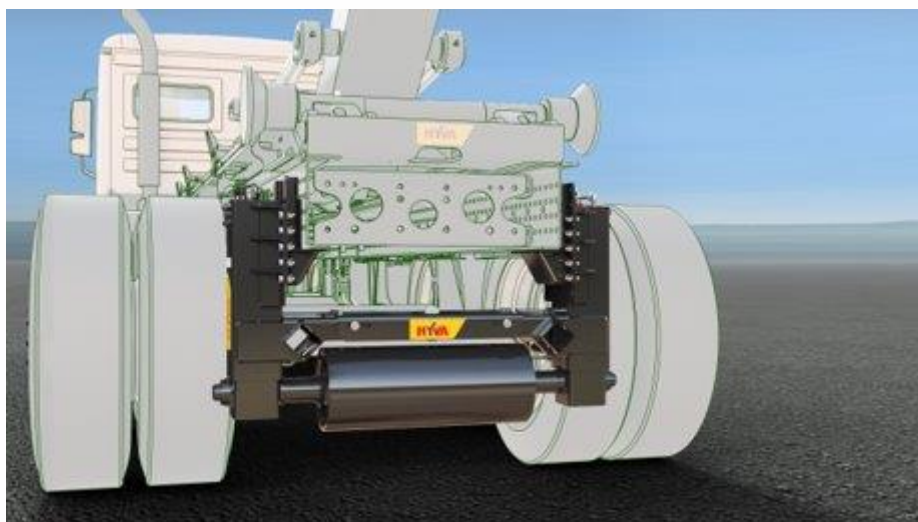

The vertical stabilizer offered by Hyva is boltable and comes painted ready out of the factory. It's available with a 270mm or a 230mm roller diameter, it is preferred to use a larger diameter in softer or muddy grounds, while the small one save you space.



For additional information please refer to:

- CH-MI-HL-0005 MOUNTING INSTRUCTION
- CH-HL-SPS-001 SPECIFICATION SHEET
- CH-HL-SPC-016 SPARE PART CATALOGUE