

EDGE LINE
RAISE YOUR GAME



ARTICULATED CRANES WITH ULTIMATE PRECISION AND LIFTING CAPACITY

HC 153 X



RAISE YOUR GAME HYVA PERFORMANCE



TOP SOLUTIONS

1

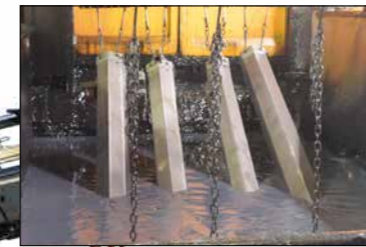

1 TPP

- **Top protection painting** - Top quality cathaphoresis treatment and paint process on all crane components ensures higher value retention and durability.
- Bolts and nuts protected by Geomet® treatment: 890% more resistance against corrosion.

Top quality protection for harsh environment

2



2 EES

- **Extra Extension Speed** - The market is always demanding more speed along with the highest possible safety. EES is the answer. Through the use of a specially designed counterbalance valve, this system increases the extension speed without affecting the crane's safety.

Save time, precise work, increase efficiency

3



3 LAS

- **Liftrod Articulating System** - Joins forged double linkages on the column and second boom. Its design raises the mechanical advantage of the articulation to provide consistent force through all working angles.

Precision and versatility for all working positions

3

4

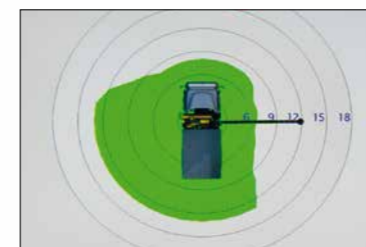

4 DLD

- **Dynamic Load Diagram** - After the stabilization, operator can select the load to be lifted. Display shows the permitted crane outreach based on the stability and the load selected.

Crane lifting capacity always under control in all stabilizer positions

5

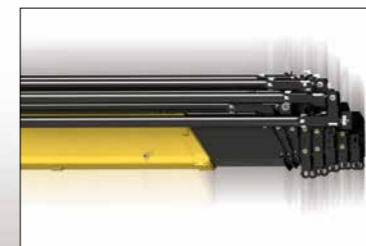

5 SDS

- **Smooth Descent System** - Uses a special counterbalance valve to reduce boom oscillation, the result for the user is incredible precision in unloading operations.

Control and precision of the movement



CRANE CONTROL SYSTEM

A

A-CLASS

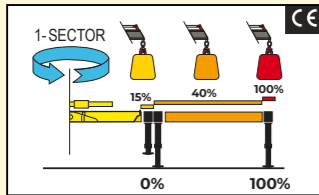

- N.2 step stabilizer beams
- N.1 sector on slewing
- Mono-area pressure limit

E

E-CLASS

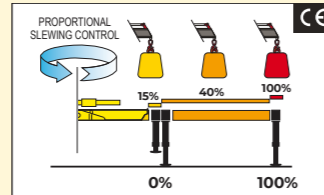

- N.2 step stabilizer beams
- Proportional slewing control
- Truck side independent

P

P-CLASS

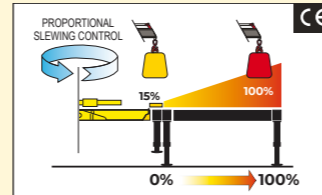

- Proportional stabilizers control
- Proportional slewing control
- Truck side independent

HUMAN MACHINE INTERFACE

L

BRIGHT LED PANEL

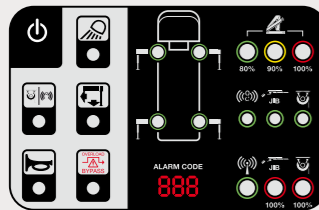

Available for the entire range till 28Tm. Highly user-friendly design, with buttons and LED lights. Dedicated led lights to identify the position of each stabilizer. New 3-digits display has been added to inform the operator about alarms and errors.

D

INTELLIGENT DISPLAY 4.3"



Up to 6 languages available. Full color new display. Offers more information and data compared to the LED Panel. The graphic design and intuitive menu guide the operator and service technician to all the functionality information, statistics and performances.

T

SMART TOP MONITOR 7"



Up to 16 languages available into the software. Top choice available for the range. Data statistics and crane management, all included into a 7" TFT monitor giving to the operator a higher level of awareness of the crane.

CRANE CONTROLS

M

MANUAL CONTROL



Crane with manual sequential controls have levers mounted on both sides of the crane. At each control station, the orientation of the controls can be the same up to down or left to right.

L

LCD REMOTE CONTROL



Each transmitter is equipped with 8 ergonomic proportional levers (6 for Scanreco mini) to control up to 8 functions of the crane. Using two hands, the operator can move 2-3-4 functions at once. This ensures more speed in loading or unloading operations with high precision.

G

GRAPHIC REMOTE CONTROL



Top visualization on 3" graphic display on the remote transmitter. Improved crane data visualization and crane control. Top level class of offer in the range.

SMART AND USER-FRIENDLY CONTROLS

Control station distinguished by operator comfort and user-friendly interface derived from dedicated ergonomic and user preference studies



SMART TOP MONITOR 7"
Simple and quick access to all the functions and information

Vertical stabilizers levers
Safe and fast. Excellent supervision of stabilizing operation

TECHNICAL SOLUTIONS TO RAISE RELIABILITY AND SAFETY

New Stability Logic for maximum level of flexibility

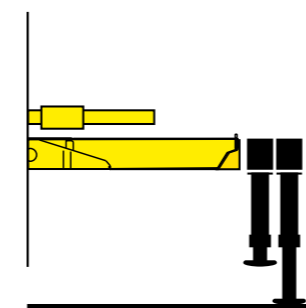

- Be free to maximize the use of your crane for all stabilizers' positions.

425° Slewing Angle for quick loading and unloading operation

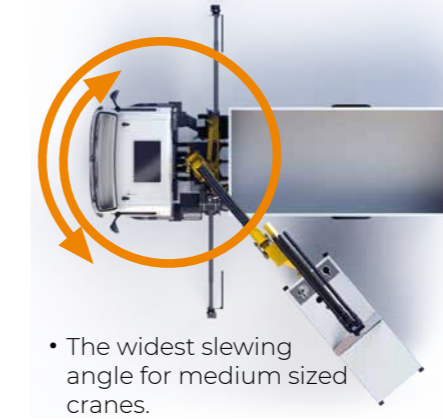

- The widest slewing angle for medium sized cranes.
- Top efficiency and easy to use.

Electronics mind: guaranteed in all conditions



- All electrical components have IP69K enclosures which offer complete protection against water jet and dust penetration providing higher durability and less down time.

OUR INNOVATIONS ARE CHANGING THE GAME

Solutions that are the result of smart engineering

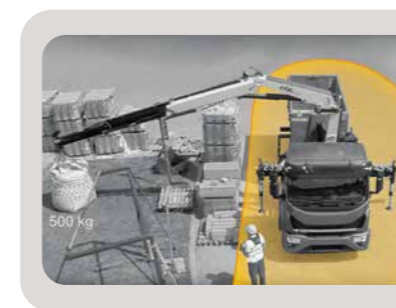

DLD DYNAMIC LOAD DIAGRAM

This system, a first on truck-mounted articulated cranes, optimises stabilisation and makes crane operation safer and more efficient, allows the driver to verify in advance the crane lifting capacity based on the truck stability. A display shows the outreach available for the load selected and the actual boom slewing position.

A TEAM OF SKILLED AND CARING SPECIALISTS

Easy installation and smart calibration cranes, combined with a high level of service, make Hyva the best partner for your business - all over the world



ONE CRANE, MANY APPLICATIONS

Thanks to the extensive range of accessories and attachments



Building



Construction



Energy



Environment



Gardening



Logistics



Maintenance



Mining



Oil&Gas



Rental

TECHNICAL INFORMATION HC153 X

Dimensions (in)

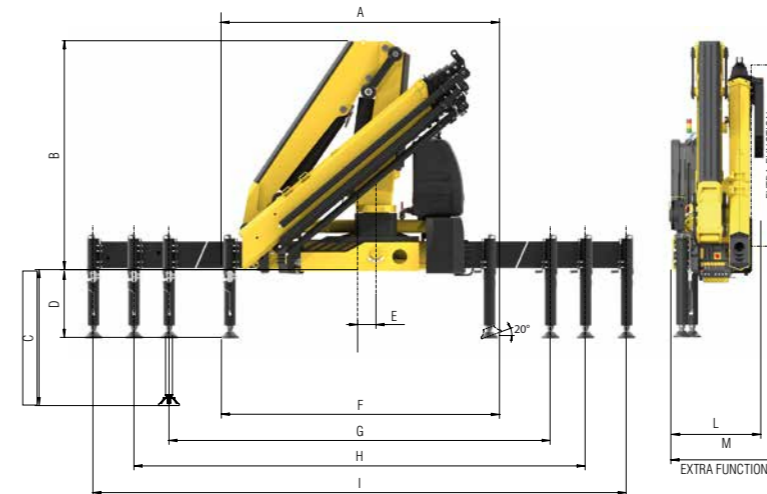

	E2	E3	E4	E5	E6	E3J2	E4J2
A	97	97	97	97	97	97	98
B	92	92	92	92	92	97	99
C	55	55	55	55	55	55	55
D	27	27	27	27	27	27	27
E	7	7	7	7	7	7	7
F	97	97	97	97	97	97	97
G	166	166	166	166	166	166	166
H	213	213	213	213	213	213	213
I	260	260	260	260	260	260	260
L	33	33	33	36	36	38	38
M	37	37	37	39	39	-	-

Load diagrams

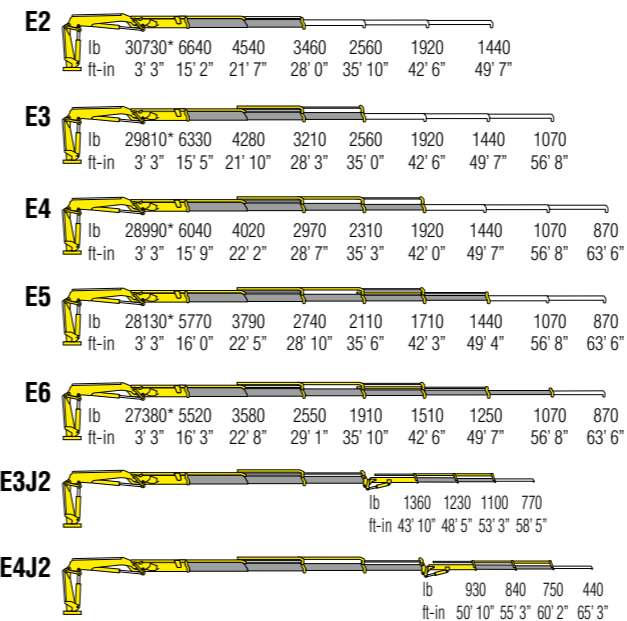

*) Theoretical lifting capacity

Standard features

- Designed in accordance with:**
EN12999:2020 + EN13849
Design class: HC1-HD5
- Multifunctional radio remote control
 - Sauer Danfoss PVG32
 - Load limit device
 - P-LCS Proportional Lift Control System
 - Flanged valves
 - Oil tank
 - Manually extendable stabilizers
 - Internal stabilizer pipes
 - Fixed stabilizer cylinders
 - Swivel stabilizer foot
 - Centralized greasing system
 - EES Extra Extension Speed
 - SDS Smooth Descent System
 - LAS Liftrod Articulating System
 - A Class - Crane Control System (CE)
 - LED panel - Human Machine Interface (CE)

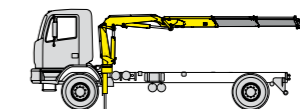

Recommended truck
G.V.W. lb 26460

Technical specifications

		E2	E3	E4	E5	E6	E3J2	E4J2
Lifting Moment	lb-ft	100500	97600	95500	92600	89700	67300	68700
Slewing Angle	°	425	425	425	425	425	425	425
Working pressure	psi	4710	4710	4710	4710	4710	4710	4710
Oil tank capacity	gal	34,4	34,4	34,4	34,4	34,4	34,4	34,4
Max Oil flow	gal/min	15,9	15,9	15,9	15,9	15,9	15,9	15,9
Max lifting height	ft-in	40' 0"	47' 3"	54' 2"	61' 4"	68' 11"	65' 3"	72' 2"
Standard crane weight	lb	4010	4265	4495	4720	4915	5015	5280

110 countries
+3,500 employees
20,000 customers
+30 subsidiaries
14 production facilities



Hyva is a leading provider of innovative and highly efficient transport solutions for commercial vehicles used in transport, construction, mining, materials handling and environmental service industries.

Founded in 1979 in the Netherlands, the company has a global presence with more than 30 wholly owned subsidiaries, extraordinary service coverage and 14 manufacturing facilities in Brazil, China, Europe and India.

For more information on Hyva, please visit www.hyva.com

or follow us on:



Hyva Corporation
 300 King Street,
 Elk Grove Village, IL 60007
 USA
 Telephone: +1 630 227 9020
 Fax: +1 630 227 9029
salesusa@hyva.com
www.hyva.com
www.hyvacrane.com



Quality and
 environmental certified



Data, descriptions, and illustrations pertain only and uniquely to models sold at the time of printing of this brochure. After the date of printing, this information is purely indicative and not binding upon HYVA. Future modifications are solely at the discretion of HYVA and are always in compliance with applicable and pertinent safety standards. To obtain updated data, descriptions, and illustrations, contact the manufacturer or your reseller. Cranes manufactured and/or marketed by HYVA. HYVA is not responsible for the special applications depicted. Crane applications and accessories described herein are only examples. Some applications and equipment shown may not be approved for use in CE countries or other areas. It is the installer's responsibility to ensure that the crane is applied correctly, and that its application, installation, and accessories maintain safety and comply with all local laws.